

Audio simplified system

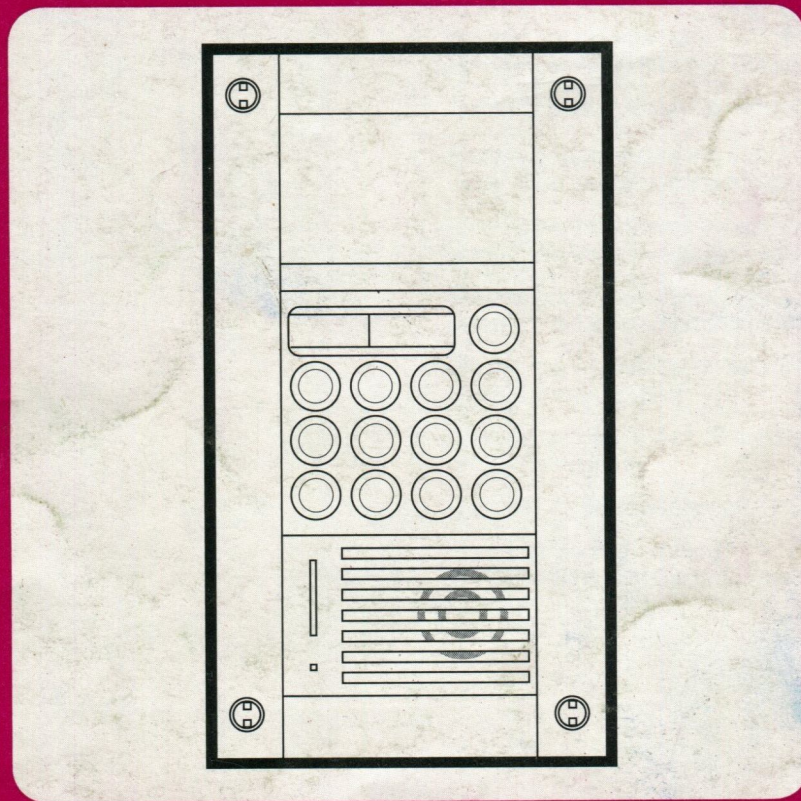

Contents

Table of intercom systems and table of electrical symbols	2
General	3
Description of Equipment	4
General Installation Requirements	10
Testing the installation	15
Troubleshooting	16
Description of installations	18
Electric porter installation with 1000 series pushbutton panels	18
Electric porter installation with Tersystem pushbutton panels	20
Electric porter installation with AV series pushbutton panels	22
Electric porter installation with numeric keypad	24
Electric porter installation with 2 external units using 1000 series pushbutton panel	26
Electric porter installation with 2 external units using Tersystem pushbutton panels	28
Electric porter installation with 2 external units using AV series pushbutton panels	30
Electric porter installation with 2 external units using numeric keypad	32
Connection diagram of 16 art. DR030 units for 256 telephones	34
Diagram for 999 telephones	35
Door lock security coding in installations with numeric keypad	36

Important











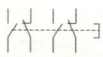





























It is recommended that only original LT accessories be used, particularly our power units. Material of other manufacturers, even if first class, may not have the characteristics required for proper operation of the equipment described in this brochure.

Due to continuous product improvement, features and specifications may be subject to change without notice.

Table of Audio Door Entry Systems

	System with 4 wires + n with buzzer	System with 1 wire + n with electronic call	
Pushbutton panels	500 series 900 series SM series AV011 - AV016 series Postalbox series Tersystem series (with 2130 + 2132 + 2141 + 2144 modules)	SM101/102/204/206 series Tersystem series (with 2191/2192/2194 modules) +Art. GE020 AV011series + 016 + Art.GE010	Digital pushbutton panel Art. AVD10+Art. GE030+Art. AVD30
Porter Speaker units	Art. 2659 Art. 2160/2161 only for Tersystem series	Built-in art. SM101/102 Art. 2170 for Tersystem series Art. 2660 for Vandal-resistant series	Incorporated in Art. AVD10
Power supply	Art. 672	Art. TE1218	Art. PS190+Art. DR030
Internal units	Art. 600/600WS/600BR 601/603N/603S/PH630WS	Art. PH620WS Art. 601CE	Art. PH620WS Art. 601CE
Switching unit for intercom	Art. 607	-	-
Two-door switching unit	Art. 608N	Art. BV020	Art. BV030+BV020
Secrecy	Art. UE611 only with art. 600	Supplied in the system	Supplied in the system
Central porter switchboard	Art. 1400/2N Art. 1500N	-	-
	Technical Bulletin No. 10	Technical Bulletin No. 12	

Table of electrical symbols

	Microphone		Double pole push-button contact		Thermistor
	Receiver		Bistable relay		Resistor
	Loudspeaker		Relay		Potentiometer
	AC buzzer		Junction box		Inductor
	DC buzzer		Integral circuit		Transformer
	AC bell		Diode		Transformer with 3 windings
	DC bell		Zener diode		Amplifier
	Lamp		Thyristor		Video distributor
	Fuse		LED Light Emitting Diode		Plug and socket
	Electromagnetic lock-door release		Bridge rectifier		Coaxial cable
	Contact		PNP transistor		Radio receiver
	Pushbutton		NPN transistor		Earth
	Locking pushbutton contact		Electrolytic capacitor		Battery
	Double pole contact		Capacitor		

General

The new intercom system, which complements the already well known system using 4 wires + n, allows for considerable simplification of the wiring between the external unit and the telephones. By using an electronic unit which is housed in the pushbutton panel, it is in fact possible to carry out installations with only one common and one signal wire for each telephone. This electronic unit also acts as a power supply and tone generator for the call signal.

Connected to the mains is a 12V transformer which supplies the power to the system.

The new PH620WS and 601CE intercoms, equipped to receive the electronic call signal, are available for use as the internal units.

The following series of external units can be used: the Tersystem series in conjunction with appropriate modules and the GE020 electronic call unit or, alternatively, the AV series in conjunction with the GE010 electronic unit, or the new 1000 series pushbutton panels, in which the speaker unit and the electronic unit are integral parts of the basic unit.

The system is equipped with secrecy and handsets mistakenly left off the hook do not affect the system.

The new system also allows the conversion of installations having only door bells installed into full intercom installations using the existing cables.

For installations with numerous telephones, a vandal-resistant numeric keypad is available by means of which the number of wires between the pushbutton panel and the riser cable may be considerably reduced; for example, 8 wires are sufficient for 48 telephones. In this case it is necessary to provide a power supply instead of a transformer, the appropriate electronic unit in the pushbutton panel and a decoder module for every 16 telephones.

In this system the electronic call sent to the telephone emits a confirmation tone at the pushbutton panel.

Internal units

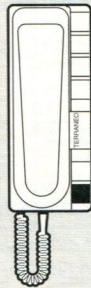
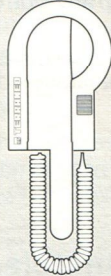

Numeric keypad

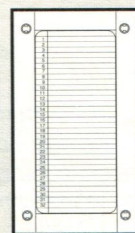
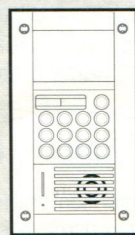

External units

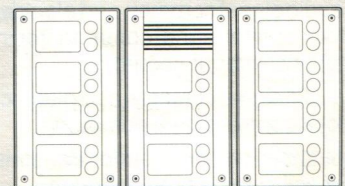
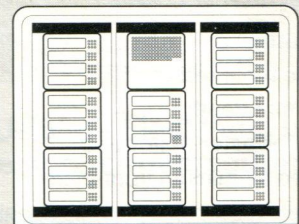
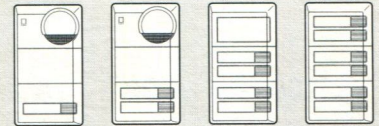

Description of Equipment

1000 Series pushbutton panels

Modular pushbutton panels which can be assembled to form any size system by using a limited number of modules.

Available finishes: natural anodized aluminium, white and brown.

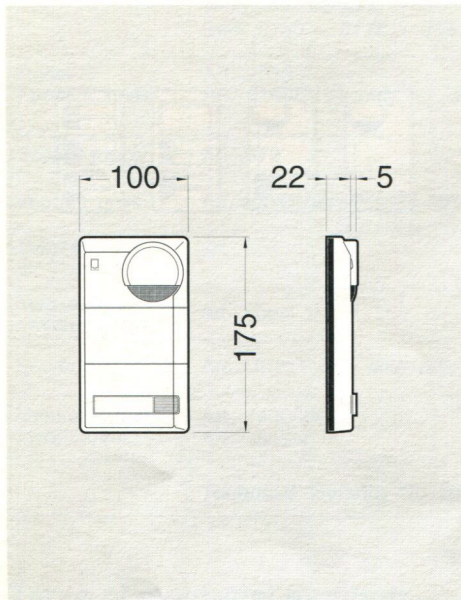

Characteristics

- surface mounted
- 22/27 mm depth
- black polyester-resin base
- pressed aluminium front-plate
- complete with speaker and electronic units, which forms part of the base
- speaker unit with electrical characteristics and terminals as per art. 2660

Connection terminals and their functions

- B Buffer battery power supply negative input
- T 12V AC transformer
- S 0V AC transformer
- 0V DC
- 17 12V AC output for electric door-release
- 14 audio signal common and electric door lock control signal common (for installations without secrecy)
- 14 audio signal common and electric door lock control signal common
- 13 pushbutton common for transmission of call signals to telephones
- 13 Calling signal output
- 14 Common to speaker unit and electric lock
- 15 12V effective values output and buffer battery power supply positive input
- 16 0V DC
- P speech and electric door lock control signal

Tersystem Pushbutton Panel

Modular pushbutton panels: by using a small number of parts appropriately assembled, it is possible to make up any type or configuration of pushbutton panel.

The figure illustrates a typical configuration. Available finishes: natural anodized aluminium, white, brown.

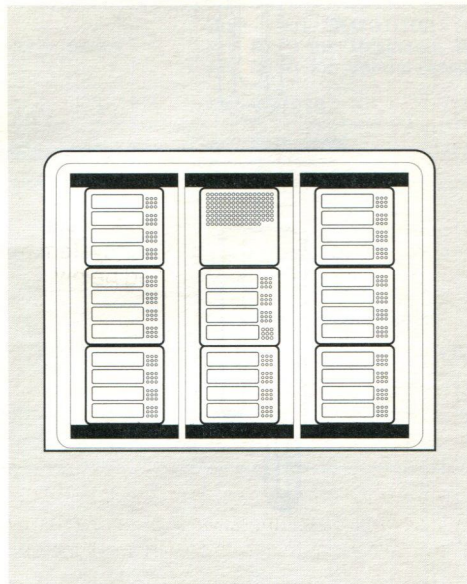

Characteristics

The system comprises the following:

- flush mounting boxes with extruded aluminium plate
- flush mounting or gate mounting weather-resistant housing
- module including "Porter" with or without "WAIT" signal
- 1, 2 or 4 pushbutton modules
- hole blanking cover modules or modules with illuminated name plates

Art. 2170 - "Porter" Module

Equipped with a potentiometer for adjustment of the sound level for transmission and a balancing potentiometer.

Available finishes:
art. 2170 natural anodised aluminium
art. 2170WS white
art. 2170BR brown

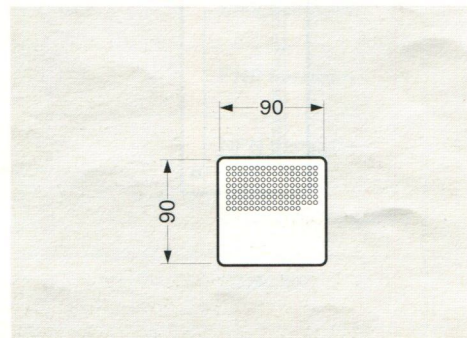

Art. 2179 - "Porter" Module

Same as art. 2170 but with "WAIT" signal for installations with 2 or more external units.

Available finishes: art. 2179 natural anodised aluminium
art. 2179WS white
art. 2179BR brown

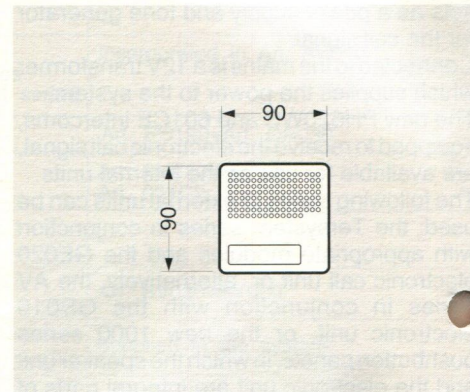

Art. 2191 - 1 pushbutton Module

Available finishes: art. 2191 natural anodised aluminium

art. 2191WS white
art. 2191BR brown

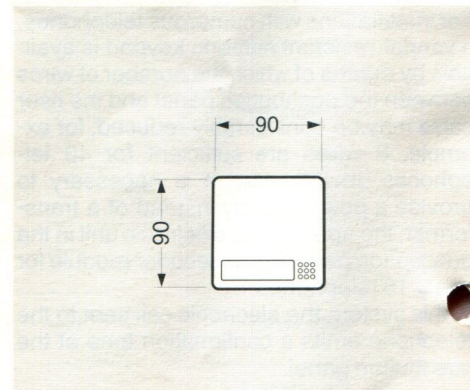

Art. 2192 - 2 pushbutton Module

Available finishes: art. 2192 natural anodised aluminium

art. 2192WS white
art. 2192BR brown

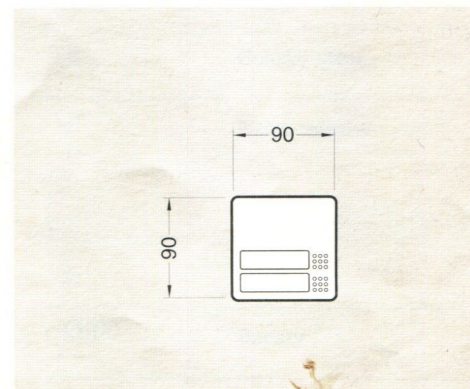

Art. 2194 - 4 pushbutton Module

Available finishes: art. 2194 natural anodised aluminium
art. 2194WS white
art. 2194BR brown

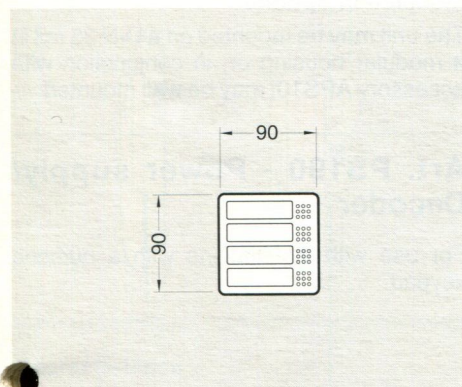

Connection terminals and associated functions

- 16 0V AC/DC
- 15 12V AC for pushbutton illumination bulb
- 14 speech common and electric door lock control signal common
- 13 pushbutton common for transmission of call signal to telephones
- P memory enable for audio signal and electric door lock control signal

Art. GE020 - Electronic power supply unit

To be incorporated in the Tersystem series pushbutton panels. This unit contains the circuitry necessary to allow the use of a single common wire and one call wire for each pushbutton for connection to the external unit.

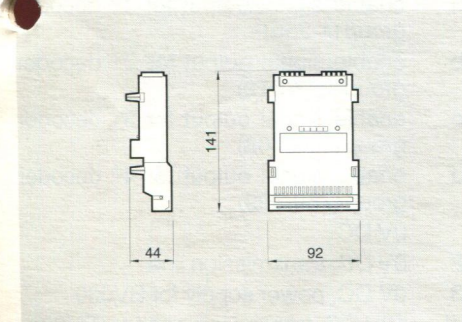

Characteristics

- 4 way connector included for connection to "Porter" module art. 2170 or art. 2179
- Weight Kg. 0.340

Connection terminals and associated functions

- S 0V AC transformer
- 18 0V AC
- T 12V AC transformer
- 15 12V AC for pushbutton panel lamps
- 16 0V DC
- 0V DC

- 17 12V AC output for electric door lock
- 13 call pushbutton common to extensions
- 14 audio signal common and electric door lock signal common
- 11 do not connect
- 12 0V AC input for "WAIT" indicator lamp

Installation options

The unit, which occupies the space of two modules, must be housed behind the "Porter" module within the Tersystem pushbutton panel.

Vandal-resistant AV series pushbutton panels

These are described in detail in the commercial catalogue and are themselves also suitable for use in the 1 wire + n intercom system by using the accessories described below.

Art. GE010 - Electronic power supply unit

To be mounted on the bottom of the flush mounting boxes of the AV series pushbutton panels prior to making good of masonry. This unit contains the circuitry necessary to allow the use of a single common wire and one call wire for each pushbutton for connection to the external unit. It offers secrecy of conversation for 6 extensions as a standard feature; for use with more than 6 extensions, the UE008 must be used for installations with secrecy of conversation.

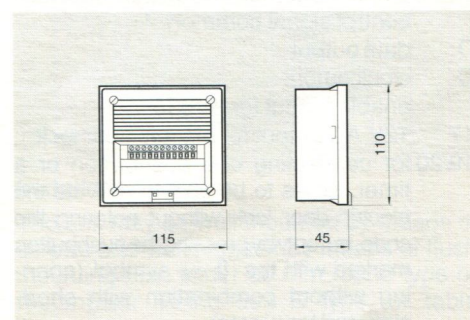

- Weight Kg. 0.320

Connection terminals and associated functions

- S 0V AC
- 0V DC
- 16 0V AC/DC
- T 12V AC, transformer and pushbutton panel lamps
- 13 call pushbutton common to extensions
- 14 audio signal common and electric door lock control signal common
- 17 12V AC output for electric door lock
- P1 porter audio signal
- P2 porter audio signal
- 14 audio signal common and electric door lock control signal common (for installations without secrecy of conversation)

- 14° speech common and electric door lock control signal common (for installations with secrecy of conversation)
- 16° 0V AC (for installations with secrecy of conversation)
- P audio signal and electric door lock control signal (for installations with or without secrecy of conversation)

Art. 2660 - Electronic "Porter"

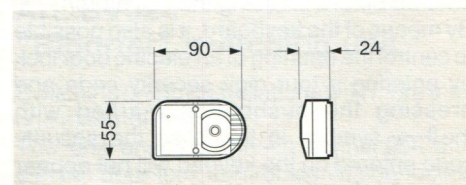

Characteristics

- Amplified electret microphone and loud-speaker
- Two potentiometers: one for volume adjustment and the other for balancing
- Weight Kg. 0.130

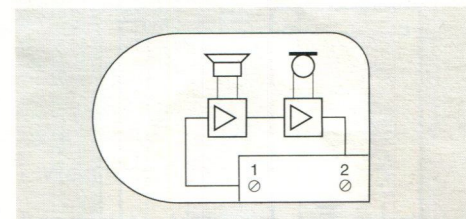

Art. UE008 - Electronic unit for secrecy of conversation

To be mounted in AV series pushbutton panels, one unit for every 8 pushbuttons, in installations with more than 6 extensions with secrecy of conversation.

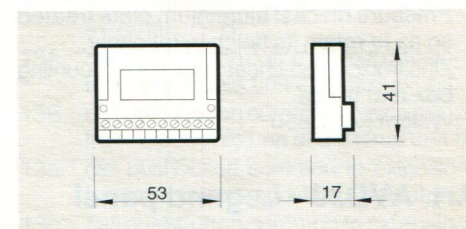

Connection terminals and associated functions

- 16 0V AC/DC
- 14 speech common and electric door lock control signal common
- P memory enable for audio signal and electric door lock control signal

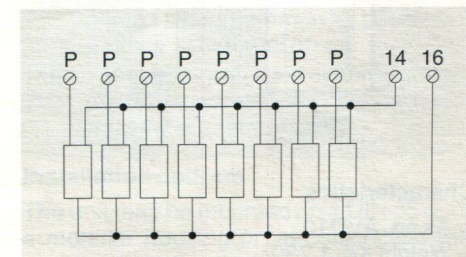

Numeric keypad

Art. AVD10 - Basic pushbutton panel

Having the same construction as the vandal-proof series, this pushbutton panel features a waterproof keypad with illuminated symbols and numbers which allows entry of the number corresponding to the required telephone to be called. The entered number appears on the display and, in the case of incorrect entry, may be cancelled and re-entered before pressing the call button.

By means of the keyboard, it is also possible to control the opening of an electric door lock by entering a four digit security code and pressing the pushbutton marked with the **0** symbol; in this case the security code entered on the keypad will not appear on the display.

The pushbutton panel is supplied complete with audio subsystem with two potentiometers: one for adjustment of the volume and the other for balancing.

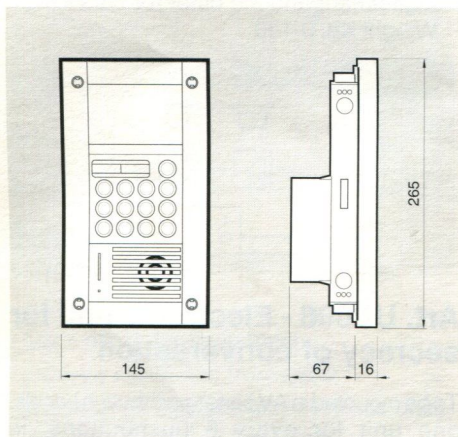

Characteristics

- Pressure diecast aluminium plate treated so as to retain its finish indefinitely.
- Zinc tropicalized sheet steel flush mounting box and frame.
- Weight Kg. 1.850

Art. AVD30 - Legend panel

To be used, if required, in conjunction with the AVD10, allowing for 32 or 64 names to be displayed with their corresponding numbers.

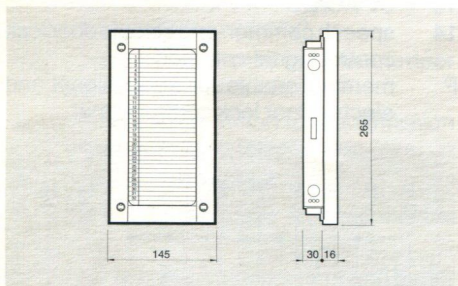

Characteristics

- As art. AVD10
- Weight Kg. 1.730

Art. GE030 - Electronic power supply unit

For installations with numeric keypads. To be mounted on the bottom of the flush mounting box for the AVD10 prior to making good of masonry.

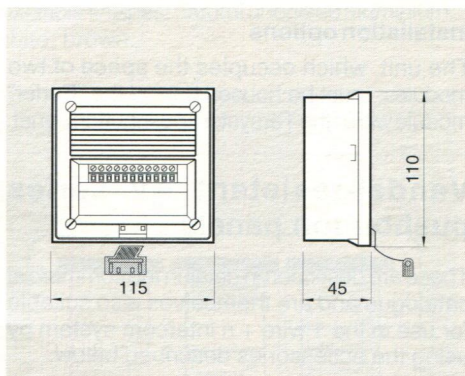

- Weight Kg. 0.320

Connection terminals and associated functions

- 15 12V AC for legend panel lamps and for electric door lock
- 16 0V AC
- T 12V AC, transformer
- S 0V AC
- 0V DC
- 2 0V DC for transmission line
- 11 12V AC for "WAIT" indicator lamp
- 12 0V AC for "WAIT" indicator lamp
- 13 call signal common to telephones
- 14 speech common and electric door lock control signal common
- D data output
- C clock output
- I enable output for BV030
- 17 12V AC output for electric door lock
- 19/20 for connecting one pushbutton or a timer, so as to be able to activate the electric door lock without entering the code, but only by pressing the pushbutton marked with the **0** symbol (opening without combination with short-circuited terminals)

Art. DR030 Decoder/Junction unit

For use with installations with numeric keypad with secrecy. The unit allows connection of 16 extensions. Included with the unit is a multi-way cable with two connectors for wiring up the unit.

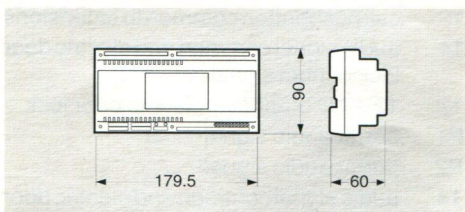

- Weight Kg. 0.310

Connection terminals and associated functions

- 1-16 speech, call signal and electric door lock control signals
- I enable input for decoder unit

Installation options

The unit may be mounted on a DIN 35 rail in a modular housing or, in conjunction with accessory APS10, may be wall mounted.

Art. PS190 - Power supply/Decoder

For use with installations with a numeric keypad.

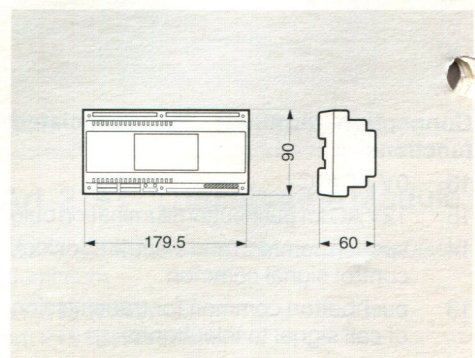

Characteristics

- Automatic short circuit and overload protection on the primary and on the secondary by means of PTC devices and fusible links
- 10 unit DIN modular housing
- Weight Kg. 1.450

Connection terminals and associated functions

- la enable signal output for 1st decoder group (1-256)
- lb enable signal output for 2nd decoder group (257-512)
- lc enable signal output for 3rd decoder group (513-768)
- ld enable signal output for 4th decoder group (769-999)
- 0V DC
- 2 0V DC, transmission line
- 3 0V DC, power supply for BV030
- +2 12V DC, transmission line for BV030
- +3 12V DC, power supply for BV030
- C clock input
- D data input
- 13 call signal common to telephones
- 14 speech common and electric door lock control signal common
- T 12V AC
- S 0V AC

Installation options

The unit may be mounted on a DIN 35 rail in a modular housing or, in conjunction with accessory APS10, may be wall mounted.

Art. PH620WS - Intercom

Intercom for use in electric "Porter" installations with 1 wire + n and with one or more external units.

Available finish: white

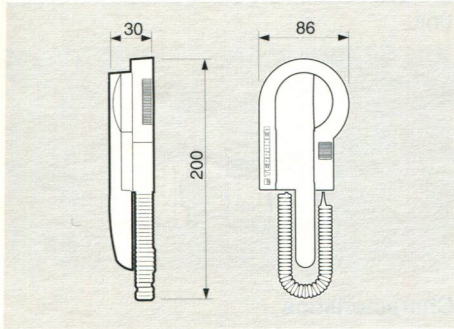

Characteristics

- Pushbutton for door opening control.
- Equipped to receive electronic call signal.
- Electret microphone.
- Weight Kg. 0.200

Connection terminals and associated functions

- 1 0V DC
- 2 output for auxiliary sounder art. 40.50N
- 4 audio signal and electric door lock control signal
- 5 do not connect

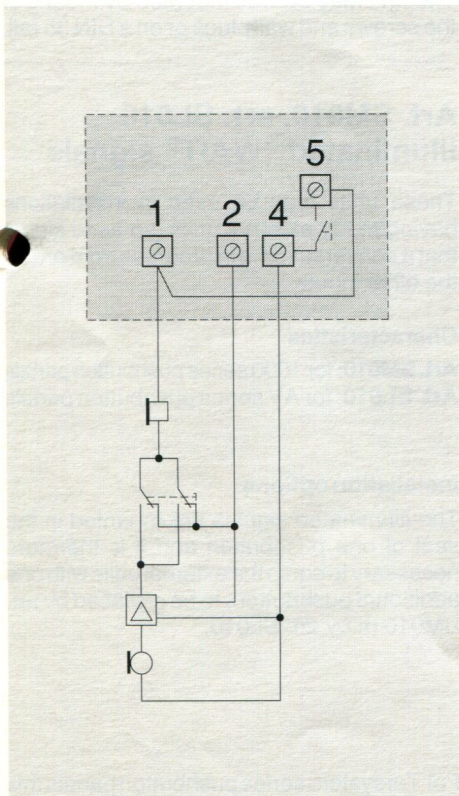

Installation options

The unit may be wall mounted by means of screws and wall plugs or by means of flush mounting box, either 60 mm round type or rectangular Ticino 503 B type.

Art. 601CE - Intercom

Intercom for use in electric "Porter" installations with one or more external units.

Available finish: beige.

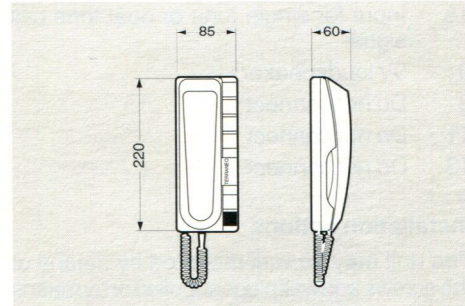

Characteristics

- Pushbutton for door opening control.
- Equipped to receive electronic call signal.
- Electret microphone.
- Weight Kg. 0.430

Connection terminals and associated functions

- 8 audio signal and electric door lock control signal
- 5 output for auxiliary sounder art. 40.50N
- 0 0V DC

Sc. 601CE.000

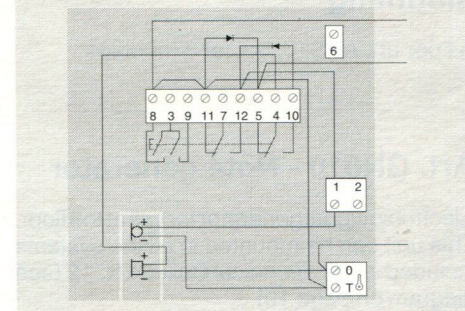

Installation options

The unit may be wall mounted by means of screws and wall plugs or by means of flush mounting box, either 60 mm round type or rectangular Ticino 503 B type, or table mounted by means of art. 600T.

Art. 600T - Base and terminal block

Weighted base including terminal block and 2.5 m of cable for table mounted installations of type 601CE intercoms. Terminal block colour: black.

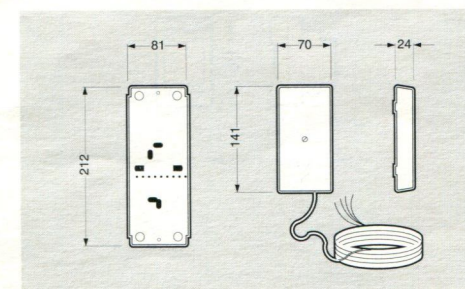

Characteristics

- The base is constructed of 2.5 mm thick zinc tropicalized steel; Weight Kg. 0.310
- 11 conductor connection cable.

Installation options

The unit may be wall mounted by means of screws and wall plugs or by means of flush mounting rectangular Ticino 503 B type box.

Art. BV020 "Biporter" switching unit

Switching unit for installations with more than one external unit.

The unit enables speech connection and electric door lock control signal connection with the external unit from which the call has been made.

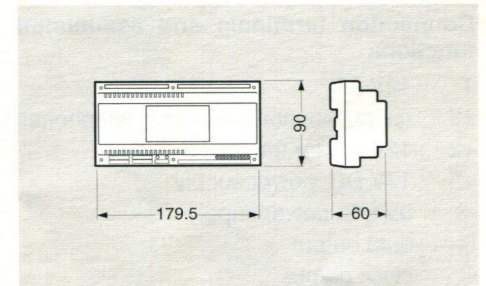

- Weight Kg. 0.310

Connection terminals and associated functions

- T 12V AC transformer
- S 0V AC
- 0V DC
- + power supply for "WAIT" indicator lamp
- 12A 0V AC for "WAIT" indicator lamp on external unit A
- 12B 0V AC for "WAIT" indicator lamp on external unit B
- 13A call pushbutton common to extensions from electronic unit at external unit A
- 13B call pushbutton common to extensions from electronic unit at external unit B
- 13a call pushbutton common to extensions from pushbutton module at external unit A
- 13b call pushbutton common to extensions from pushbutton module at external unit B
- 14A speech common and electric door lock control signal common from electronic unit at external unit A
- 14B speech common and electric door lock control signal common from electronic unit at external unit B
- 14a speech common and electric door lock control signal common for pushbutton module at external unit A
- 14b speech common and electric door lock control signal common for pushbutton module at external unit B

Installation options

The unit may be mounted on a DIN 35 rail in a modular housing or, in conjunction with accessory APS1, may be wall mounted.

Art. BV030 - Adaptor

Adaptor to be used in installations with numeric keypad and two external units in conjunction with the "biporter" switching unit BV020.

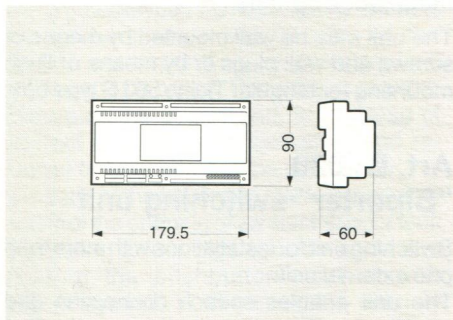

- Weight Kg. 0.300

Connection terminals and associated functions

T	12V AC
13	call pushbutton common to telephones
+2	12V DC for transmission line
+3	12V DC, power supply
-3	0V DC, power supply
D	data output
C	clock output
13a	call pushbutton common to telephones from external unit A
13b	call pushbutton common to telephones from external unit B
12A	input to disable external unit A
12B	input to disable external unit B
DA	data input from external unit A
DB	data input from external unit B
CA	clock input from external unit A
CB	clock input from external unit B
IA	enable input from external unit A
IB	enable input from external unit B

Installation options

As for art. BV020.

Art. 40.50N Electronic auxiliary sounder

This unit allows for distribution of the call tone to other areas of the same dwelling.

Characteristics

Electronic call signal differentiated according to external unit and floor.

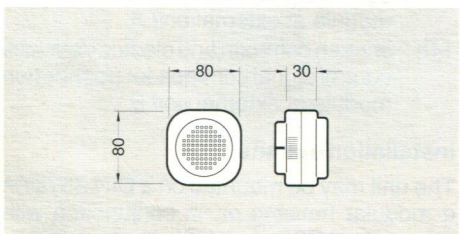

Connection terminals and associated functions

7	Do not connect
17	Do not connect
8	Do not connect
18	Input for single tone or dual tone call signal
0	0V loudspeaker
3	Do not connect
11	Do not connect
13	Do not connect

Installation options

The unit may be wall mounted by means of the screws and wall plugs supplied or by means of a 60 mm diameter flush mounting box.

Art. APS10 - Accessory for wall mounting

This accessory allows wall mounting of items in 10 unit modular housings. It comprises a DIN 35 rail to accommodate 10 modules, terminal block protective covers, screws and wall plugs.

Art. APS3 - Accessory for wall mounting

As per art. APS10, but for 3 modules

Art. GN010 - Note generator

Electronic signal generator for call at the floor. This unit can be mounted in all the systems included in the Technical Bulletin N. 12 (see diagram on page 10).

Characteristics

- DIN modular housing 3 modules

Installation options

The unit may be mounted on a DIN 35 rail in modular housing or, in conjunction with accessory APS3, may be wall mounted.

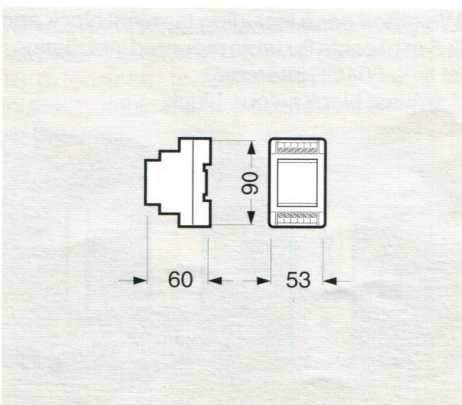

Art. 40.92 - Relay

Relay with a closed contact and a changeover contact to be used for each of the controls: illuminating lamps, electromagnetic locks supplied with voltages other than those which are available on the electronic power supply unit.

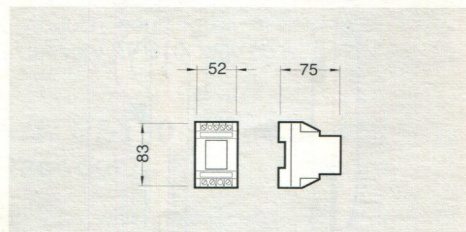

Characteristics

- Power supply 12V AC or DC
- Contacts 5A 220V
- DIN housing 3 modules

Connection terminals and associated functions

+/~	12V AC or DC
-/~	12V AC or DC
3/4	NO contact
1/5	NC change-over contact
1/2	NO change-over contact

Installation options

The unit may be wall mounted by means of the screws and wall plugs or on a DIN 35 rail.

Art. SM010, art. SL010 Illuminated "WAIT" signals

These units may be used in installations having many external units, so as to signal that a conversation is in progress from one of the other inputs.

Characteristics

Art. SM010: for 1000 series pushbutton panels
Art. SL010: for AV series pushbutton panels

Installation options

The illuminated signals are mounted in the seat of one pushbutton and it is therefore necessary to equip the external units with one additional pushbutton, to be replaced by art. SM010 or by art. SL010.

For Tersystem series pushbutton panels this illuminated signalling may be obtained by using the information module art. 2149 provided with "WAIT" unit.

It is therefore necessary to equip the external unit with one additional module, whose position will be taken by art. 2149.

Notes

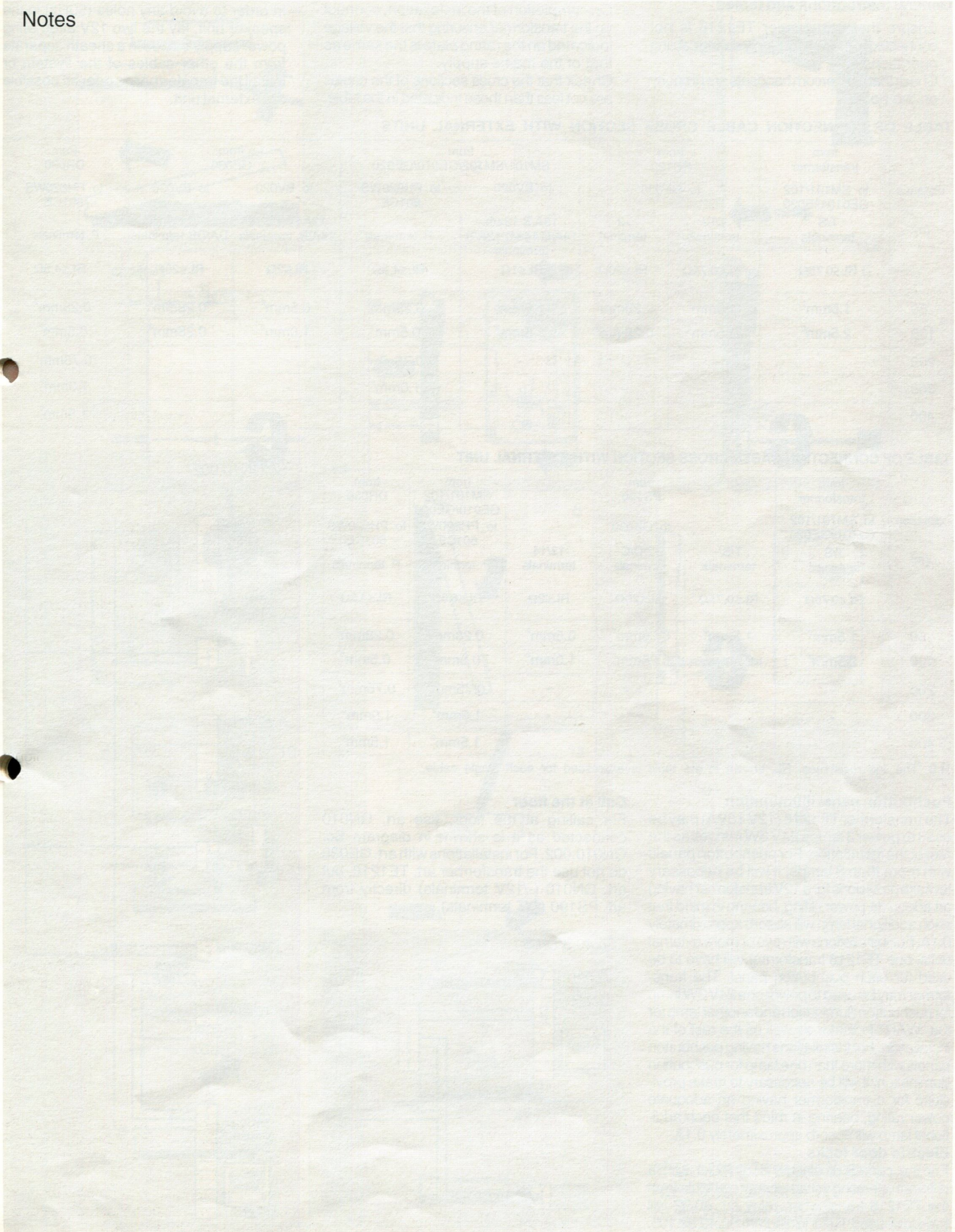

General installation requirements

General instructions and tables

- Ensure that transformer TE1218 is not connected to the mains supply during cabling operations.
- Check that all intercom handsets are properly on the hook.

- On completion of the installation, connect up the transformer ensuring that the voltage indicated on the rating plate is the same as that of the mains supply.
- Check that the cross sections of the cables are not less than those indicated in the table.

- In order to avoid any noise (50Hz) in the speaker unit, lay the two 12V alternating power supply cables in a sheath separate from the other cables of the system or install the transformer as near as possible to the external unit.

TABLE OF CONNECTION CABLE CROSS SECTION WITH EXTERNAL UNITS

distance (m)	from transformer to SM101/102 GE010/GE020	from PS190 to GE030		from SM101/SM102/GE010/GE020 to BV020		from GE030 to BV020		from DR030 to PH620WS 601CE
	T/S terminals RL≤0.75Ω	T/S/- terminals RL≤0.75Ω	-2 terminal RL≤20Ω	13A/B 13a/b 14A/B 14a/b 12A/B terminals RL≤1Ω	P terminals RL≤4.5Ω	12A/B 13A/B 14A/B terminals + RL≤2Ω	1A/IB CA/CB DA/DB terminals RL≤20Ω	P terminals RL≤4,5Ω
50	1.5mm ²	1.5mm ²	0.28mm ²	1.0mm ²	0.28mm ²	0.5mm ²	0.28mm ²	0.28mm ²
100	2.5mm ²	2.5mm ²	0.28mm ²	1.5mm ²	0.5mm ²	1.0mm ²	0.28mm ²	0.5mm ²
200	-	-	-	-	0.75mm ²	-	-	0.75mm ²
300	-	-	-	-	1.0mm ²	-	-	1.0mm ²
400	-	-	-	-	-	-	-	1.5mm ²

TABLE OF CONNECTION CABLE CROSS SECTION WITH EXTERNAL UNIT

distance (m)	from transformer to SM101/102 GE010/GE020	from PS190 to GE030		from SM101/102 GE010/GE020 to PH620WS 601CE	from DR030 to PH620WS 601CE	
	T/S terminals RL≤0.75Ω	T/S/- terminals RL≤0,75Ω	-2/D/C terminals RL≤20Ω	13/14 terminals RL≤2Ω	P terminals RL≤6.5Ω	P terminals RL≤4.5Ω
50	1.5mm ²	1.5mm ²	0.28mm ²	0.5mm ²	0.28mm ²	0.28mm ²
100	2.5mm ²	2.5mm ²	0.28mm ²	1.0mm ²	0.5mm ²	0.5mm ²
200	-	-	-	-	0.75mm ²	0.75mm ²
300	-	-	-	-	1.0mm ²	1.0mm ²
400	-	-	-	-	1.5mm ²	1.5mm ²

N.B. The line resistance, RL, shown in the table is expressed for each single cable.

Pushbutton panel illumination

The transformer TE1218 (12V 18VA) may be used to power 3 lamps 24V 3W as well as the rest of the installation. For pushbutton panels with more than 3 lamps, it will be necessary to make provisions for a 12V transformer having an adequate power rating, bearing in mind that each additional lamp will absorb approximately 0.1A. For installations with two or more external units, one TE1218 transformer will have to be used for each pushbutton panel. The transformer may be used to power one 24V 3W lamp for pushbutton illumination and another lamp for the "WAIT" indicator as well as the rest of the installation. For installations having pushbutton panels with more than one lamp for pushbutton illumination, it will be necessary to make provisions for a transformer having an adequate power rating, bearing in mind that each additional lamp will absorb approximately 0.1A.

Electric door locks

For the control of electric door locks with a different operating voltage to that available from the TE1218 transformer, relay art. 40.92 will have to be used. Refer to diagram Sc. 40.92.105.

Call at the floor

For calling at the floor, use art. GN010 connected as it is shown in diagram Sc. GN010.002. For installations with art. GE030 do not use the transformer art. TE1218, but art. GN010 (-/12V terminals) directly from art. PS190 (S/T terminals).

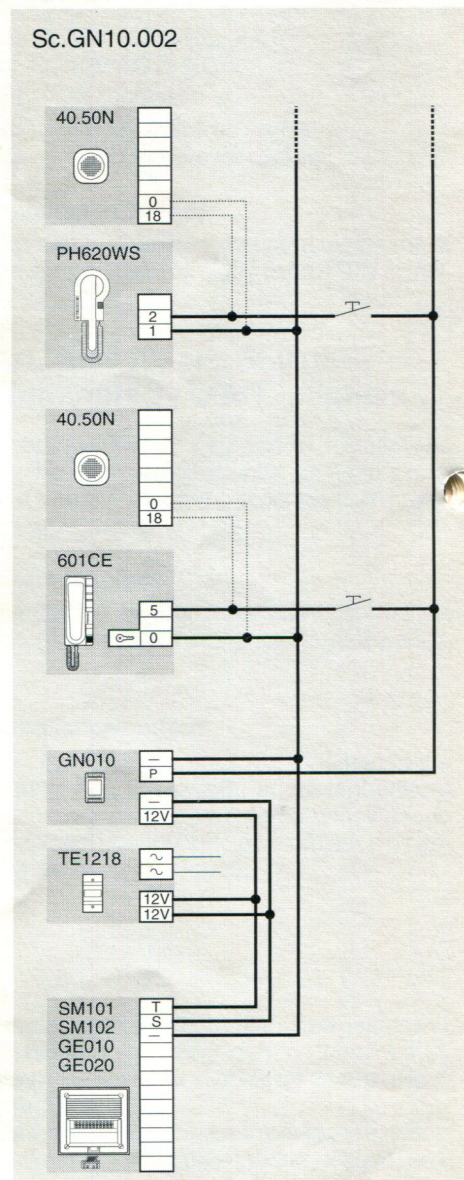
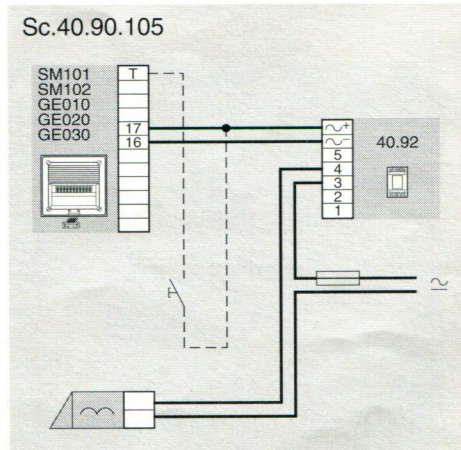

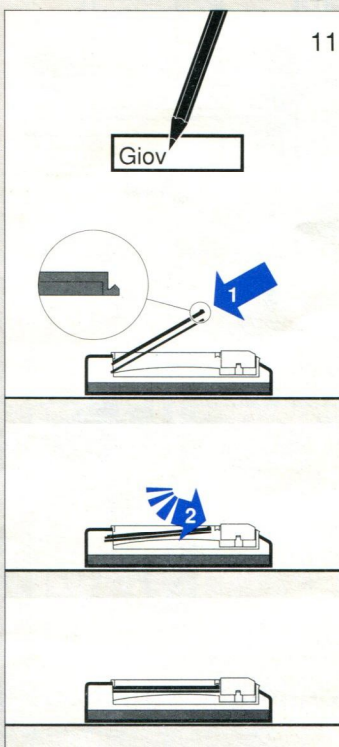
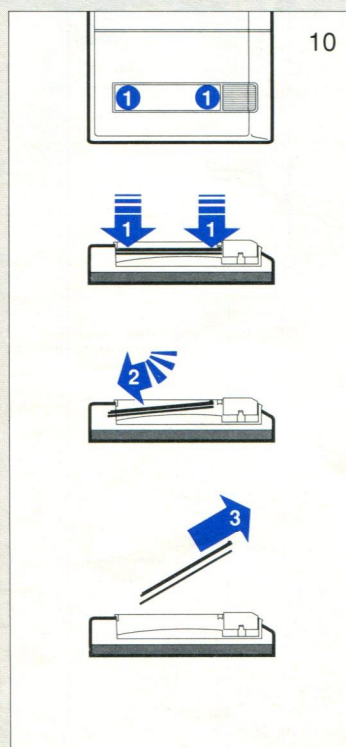
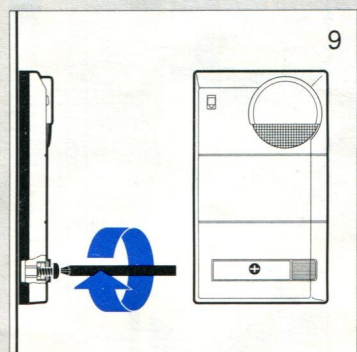
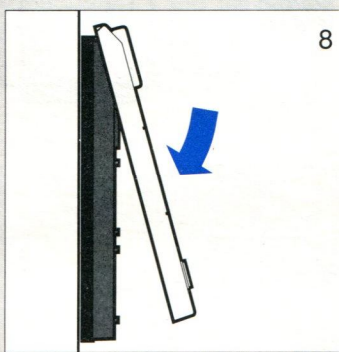
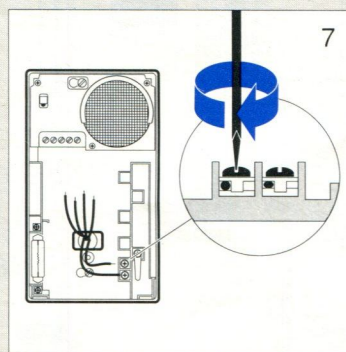
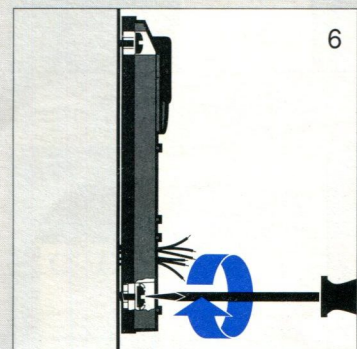
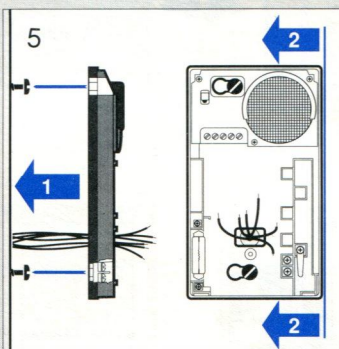
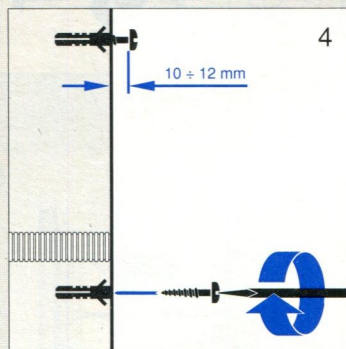
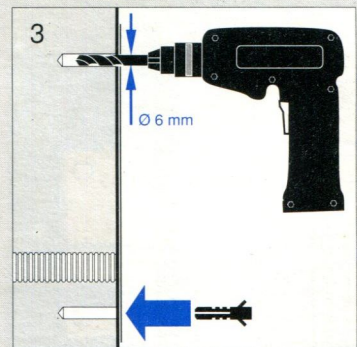
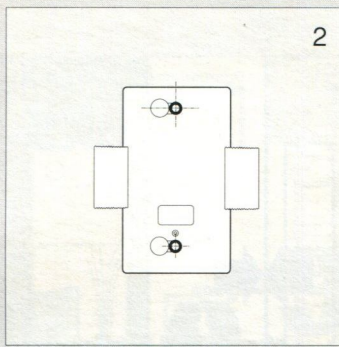
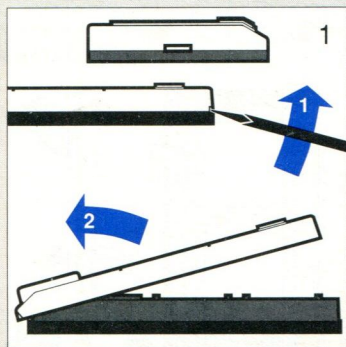

Mounting instructions
for 1000 Series
pushbutton panels

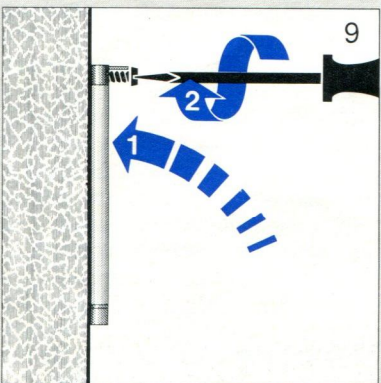
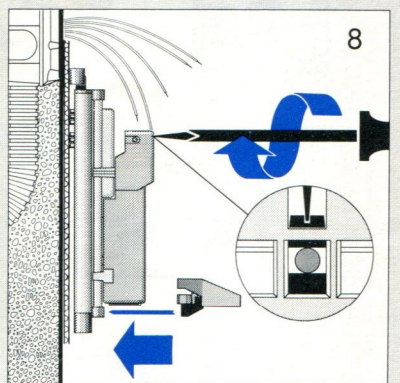
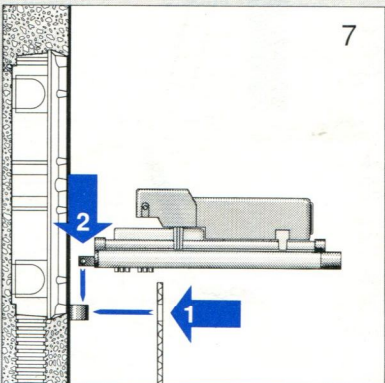
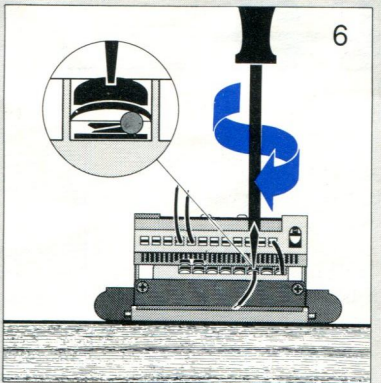
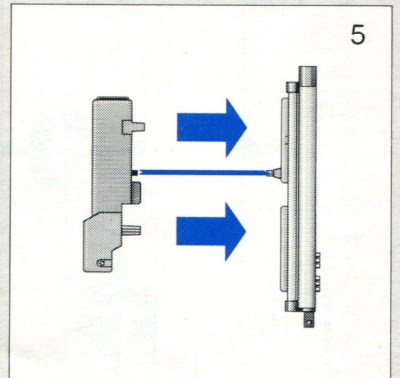
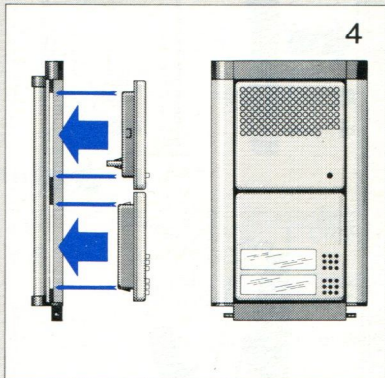
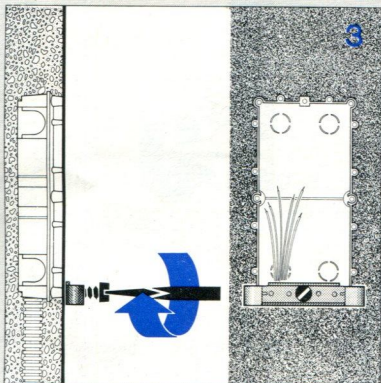
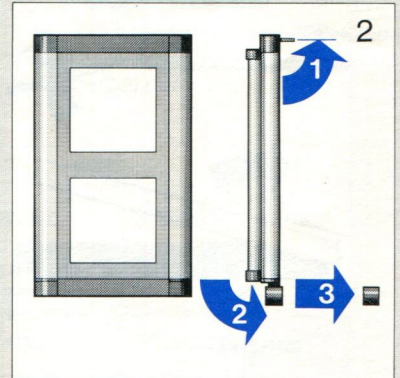
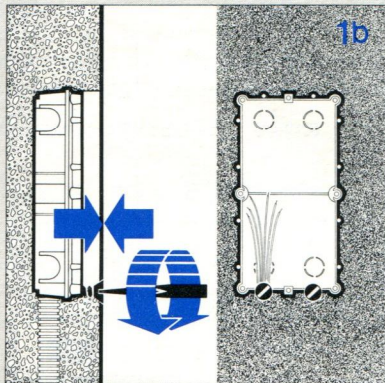
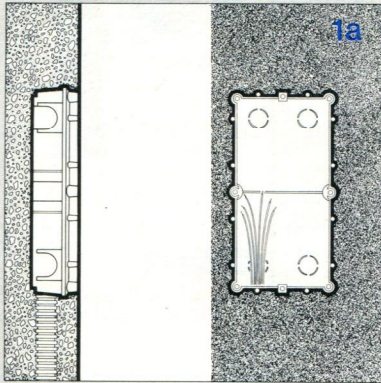

Mounting instructions for GE020

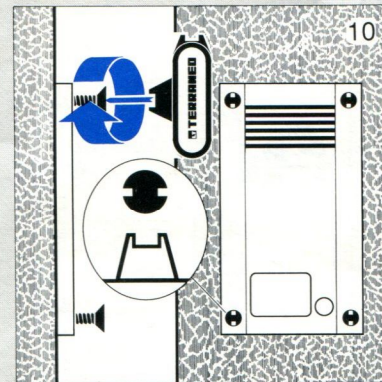
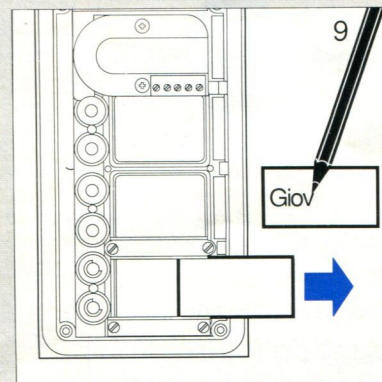
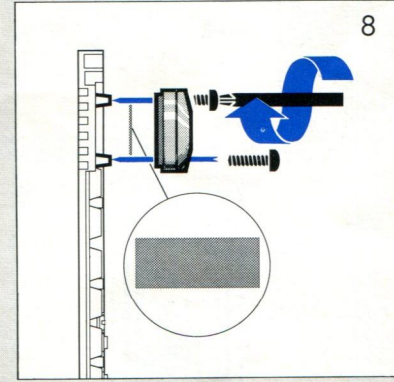
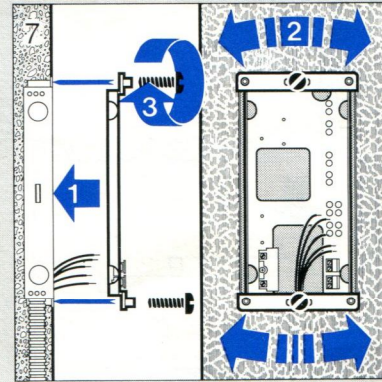
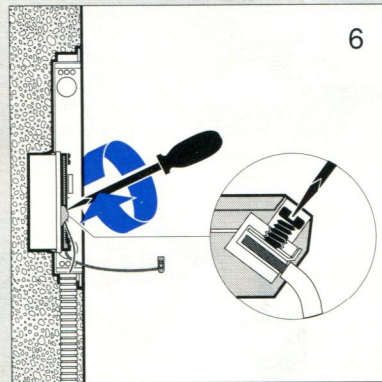
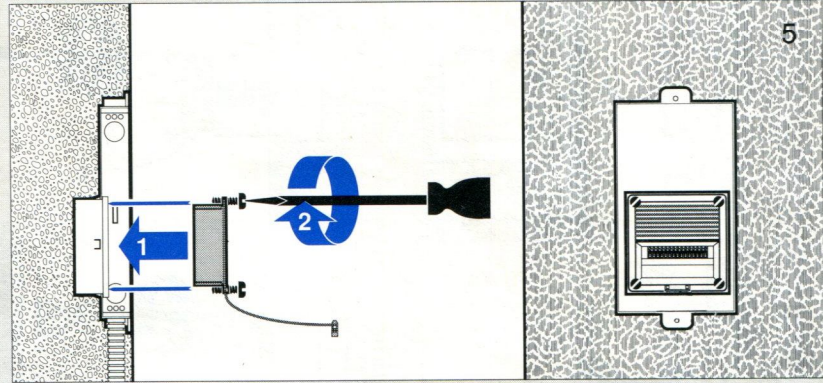
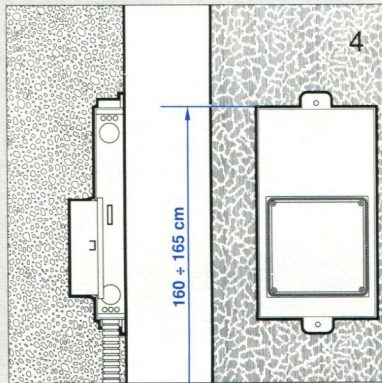
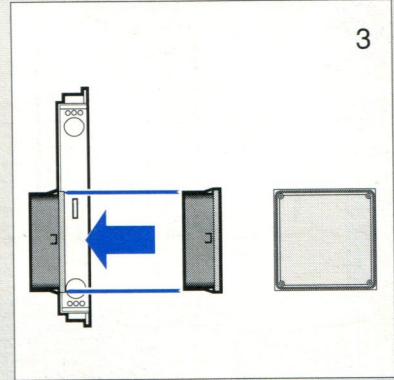
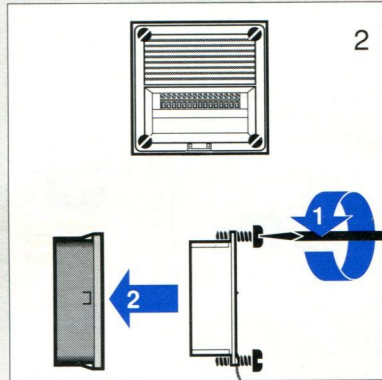
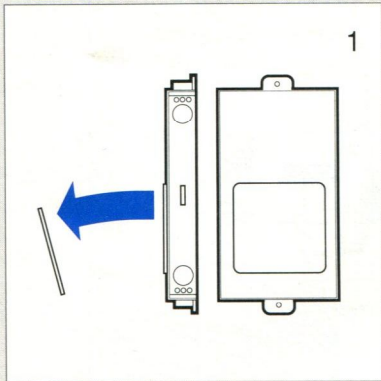

Mounting instructions
for GE010, AV series

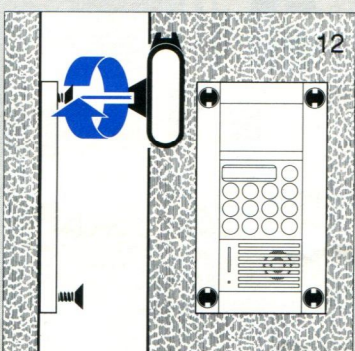
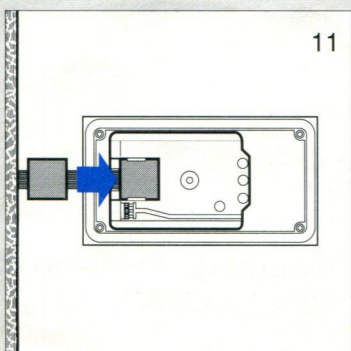
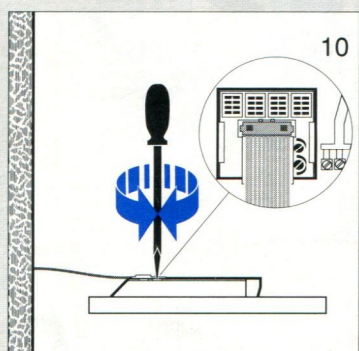
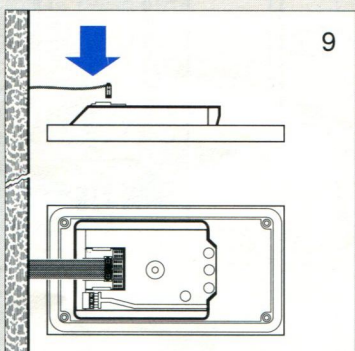
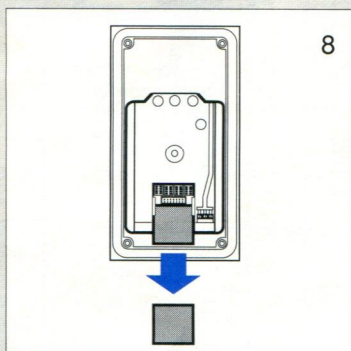
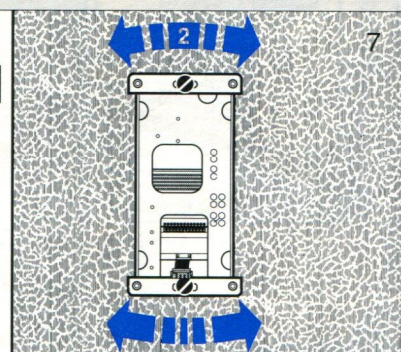
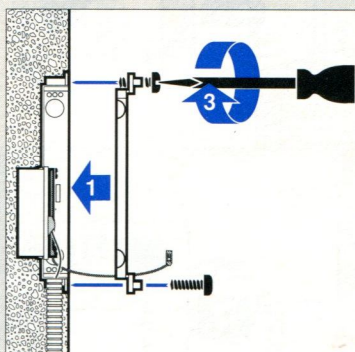
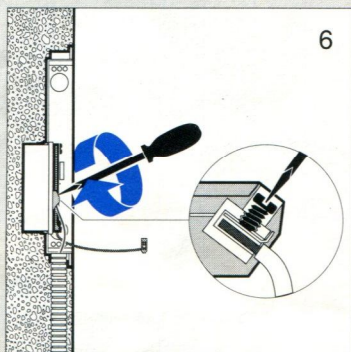
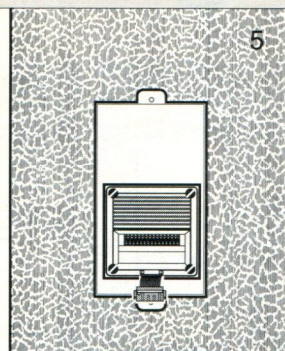
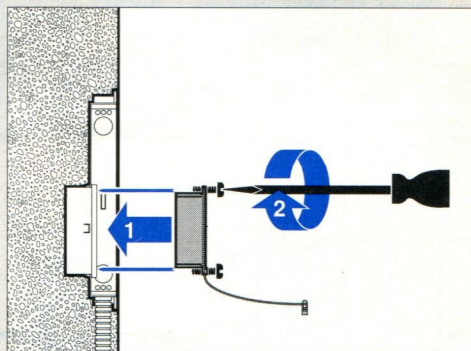
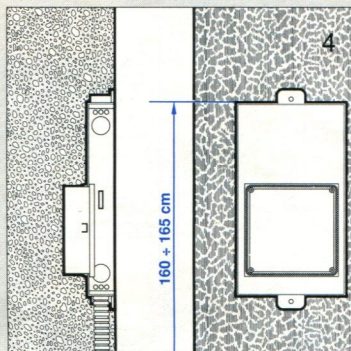
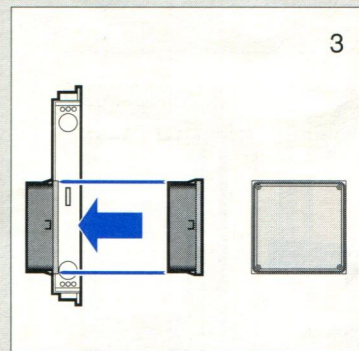
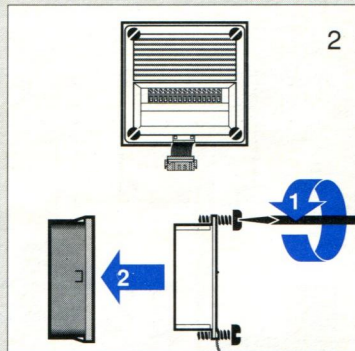
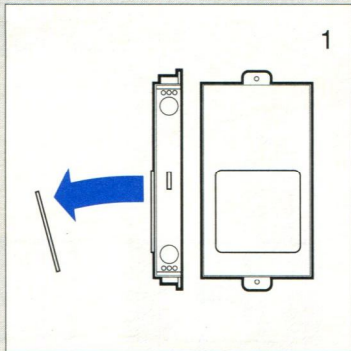

**Mounting instructions
for numeric keypad
with GE030**



Testing the installation

The procedures described below should be carried out after all connections have been made in accordance with the installation procedures described previously.



Preliminary procedures

Ensure that the connections of the installation are carried out in accordance with the relevant diagram and that transformer TE1218 is correctly connected to the mains supply. Check the audio connection with the external unit and the operation of the electric door lock.

Testing of audio section, "porter" modules art. 2170/2179



The "porter" modules art. 2170 and 2179 are equipped with two potentiometers; one for adjustment of transmission  and one for balancing . In order to adjust the potentiometers, insert a screwdriver with a 2.5 mm blade into the holes in the grille shown in the figure below.

Calibration procedure

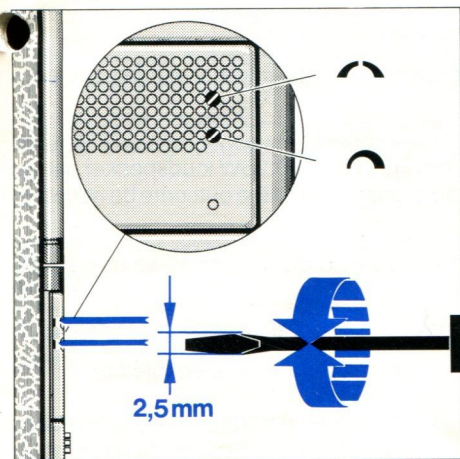
- 1) Set the balancing potentiometer with the  symbol to approximately half way.
- 2) Increase the setting of the transmission adjustment potentiometer with the  symbol so as to reach the feedback limit.
- 3) Adjust the balancing potentiometer so as to remove the instability. (pos. 1)
- 4) If difficulty is experienced in removing the instability, reduce the transmission level by adjusting the transmission level potentiometer of pos. 2



Testing of audio section, "porter" art. 2660 and speaker unit pushbutton panels art. SM102, SM102

For calibration of this unit, proceed as described for units 2170/2179, bearing in mind that the two potentiometers,  and , are accessible from the rear of the "porter" art. 2660 and under the front plate of artt. SM101, SM102.

Notes

Troubleshooting

Should any malfunction occur during operation, carry out the following preliminary checks:
 - check that transformer TE1218 is connected

to the mains
 - check that the effective voltage output from TE1218 is approximately 12V

- check that the cross sections of the cables used are in accordance with those indicated in the table on page 10.

FOR INSTALLATIONS WITH A SINGLE EXTERNAL UNIT

DEFECT

There is no reception in the entire installation

PROBABLE FAULT

The wires connected to terminals -/14 of the power supply art. GE010 or GE020 are not properly connected or are intermittent

Check across terminals -/14 on art. GE010 or GE020 or SM101/102 for a voltage of approximately -20V DC on standby. When the audio section is activated, this voltage should become approximately -7V DC. If there is no voltage across these terminals, replace art. GE010, GE020 or SM101/102.

The reception at the external unit is poor from one of the intercoms

The microphone in the particular intercom is faulty. Replace

The reception at the external unit is poor from all the intercoms

The "porter" loudspeaker amplifier is not functioning correctly and is probably faulty. Replace the "porter".

Reception is poor in one of the intercoms

The receiving capsule is faulty. Replace

Reception is poor in all the intercoms from the external unit

The "porter" microphone gain has been set too low. See on page 15.

The "porter" microphone amplifier is not functioning correctly and is probably faulty. Replace the "porter".

Transmission between the external unit and the intercoms is poor in either direction

The "porter" gain has been set too low. See procedure on page 15.

Some of the handsets have not been correctly replaced on the hook

The two wires connected to the "porter" terminals have been inverted

The "porter" is not amplifying adequately and is probably faulty. Replace

There is no reception in one of the intercoms

The wires connected to terminals of the intercom concerned are not properly connected or are intermittent or are inverted

There is a background noise in one of the intercoms

The connections to the microphone and to the receiver of the unit are suspect

The intercom changeover contacts of the internal unit are defective. Replace unit

Hum at 50Hz is present in the entire installation

The system wiring has been laid adjacent to mains wiring carrying heavy loads for long lengths.

The audio subsection power supply (terminals - and 14 of art. GE010, GE020 or SM101/102) has an unacceptable level of mains ripple. The power supply is defective. Replace.

The call signal from an external unit does not reach an internal telephone

The handset is not 'on hook'.

The loudspeaker of the intercom concerned is defective. Replace

The pushbutton on the external unit which corresponds with the internal unit concerned is defective. Replace the pushbutton.

The call signal from the external unit does not reach any of the internal telephones

Check that a voltage level of approximately 12V AC is present between terminals T and S of art. GE010, GE020 or SM101/102. Place a 50 Ohm impedance 0.25W loudspeaker across terminals - and 13 and check for the two tone audio signal. Should the outcome be negative, replace art. GE010, GE020 or SM101/102.

A feedback whistling sound is heard at the external unit

Adjust the volume and balancing of the "porter". Refer to the calibration procedure on page 15.

The electric door lock is inoperative

The flexible cable which connects the door lock mechanism to the junction box is defective.

For installations with secrecy of conversation, the electric door lock is enabled only if the secrecy of conversation is activated.

Momentarily link terminals - and 14 of art. GE010, GE020 or SM101/102 and check that there is a voltage of approximately 12V AC_{RMS} across terminals 17 and 18. Should the outcome be negative, replace the article.

FOR INSTALLATIONS WITH TWO EXTERNAL UNITS

DEFECT

One of the external pushbutton panel units is permanently disabled

PROBABLE FAULT

The call cable of the disabled pushbutton unit is damaged or incorrectly connected.

Check that there is a supply voltage of approximately 12V AC across terminals T and S of the changeover switch art. BV020.

Check the connection of the - terminal with power supply art. GE010, GE020 or SM101/102.

Audio is present on the pushbutton unit not currently calling

The wires concerned with the audio have been inverted (terminals 14A and 14B of art. BV020).

The pushbutton unit not currently calling is not disabled

The changeover switch art. BV020 does not changeover because it is defective. Replace.

After having sent a call, it is necessary to wait approximately 1 minute before repeating it

The handset of an internal unit is not properly on the hook. After the first call, the 0V signal sent by this internal telephone activates the timed disable of art. BV020.

FOR INSTALLATIONS USING DIGITAL NUMERIC KEYPADS IN CONJUNCTION WITH A SINGLE EXTERNAL UNIT

DEFECT

PROBABLE FAULT

The call does not reach any internal unit

The CLOCK DATA and GROUND connections between the external unit and the PS190 unit are incorrect.

There is no power to the DR030 modules. Check that a voltage level of 12V DC is present between the terminals marked +3 and -3 on the PS190 unit. If this voltage level is not present, replace the PS190 unit.

The connector between the PS190 and the DR030 units has not been inserted.

The connection between the PS190 unit Ia output and the I input to the first DR030 unit has not been made.

No power is connected to the external unit (check the voltage level between terminals S and T on the GE030 unit; if this is absent, replace the PS190 unit).

The DIP-SWITCHES have not been selected.

The call signal does not reach an internal telephones

The call cable of the internal unit concerned is open circuit.

The DR030 unit concerned is defective. Replace.

The internal unit concerned does not correspond to the number entered on the digital keypad.

Several internal telephones connected to different DR030 units ring together

The same number selection has been set on different DR030 units.

Some of the DR030 units are defective. Replace.

The electric door lock at the external unit's location does not operate

The code entered does not correspond to the code set on the DIP-SWITCHES.

The external unit is defective. Replace the AVD10 unit.

The power supply voltage is inadequate (check the voltage level present between terminals T and S on the GE030 unit, which should be 12V AC).

No numbers are displayed on the external unit

No power is connected to the GE030 unit (check the voltage level between terminals T and S of the GE030 unit, which should be 12V AC).

The external unit is defective. Replace the AVD10 unit.

The call signal functions correctly but the audio and the electric door lock signals do not

The - terminal of the PS190 unit has not been connected to the - terminal of the GE030 unit.

The DR030 modules, the audio and the electric door lock signals of one internal unit do not work

The DR030 unit is defective. Replace.

FOR INSTALLATIONS USING DIGITAL NUMERIC KEYPADS IN CONJUNCTION WITH TWO EXTERNAL UNITS

DEFECT

PROBABLE FAULT

There is no call present from either pushbutton panel

There is no power to the BV030 unit. Check that a voltage level of 12V DC is present between terminals +3 and -3 and between terminals +2 and -2 of the PS190 unit.

The BV030 unit is defective. Replace.

The CLOCK and DATA connections between the PS190 unit and the BV030 unit are missing.

The DATA and CLOCK connections are inverted.

The I wire connections between the external units and terminals Ia and Ib of the BV030 unit are missing.

Even when the "WAIT" indicator is lit, the keypad allows calls to an internal unit

The DATA and CLOCK connections of the two keypads to the BV030 unit have been inverted

Calls are possible only from one external unit

The BV030 unit is defective. Replace.

The CLOCK and DATA connections have been inverted.

The I wire is missing between an external unit and terminals Ia or Ib of the BV030 unit.

Description of installations

Electric porter installation with 1000 series pushbutton panels

Features

The installation allows conversation between the internal telephones and the electric porter. When the visitor at the entrance of the building presses the pushbutton on the pushbutton panel, an electronic call signal is sent to the selected internal telephone. The recipient may lift the handset and initiate a non timed conversation. The door opening control may be operated even with the handset on the hook.

The installation is provided with secrecy.

By pressing a key on the pushbutton panel, only the selected internal telephone is activated and all the others are disabled.

This type of installation has the further advantage that, if at the end of the conversation the handset is not properly replaced on the hook, the internal telephone is automatically disabled from any subsequent call in such a way as not to bring about the lowering of the audio level of the entire installation.

Implementation of the installation

a) Select the required items by reference to table 1.

In the diagram, intercom art. PH620 and intercom 601CE are foreseen.

b) Lay the cables in accordance with the connection diagram Sc. SM102.003 in which the number of wires necessary for connection of the units is indicated.

It should be remembered that the cables should be of sufficient cross section for their length, as indicated in the table on page 10.

c) Install and connect the units as shown in the diagram Sc. SM102.002 observing the installation requirements layed out on page 15.

d) Test the installation as described on page 15.

The connections for the following optional facilities are shown in the diagram with dotted lines:

- additional sounder art. 40.50N
- pushbutton for actuating the electric door lock from the hallway.

The transformer TE1218 (12V 18VA) may be used to power 3 lamps 24V 3W as well as the rest of the installation. For pushbutton panels with more than 3 lamps, it will be necessary to make provisions for a 12V transformer having an adequate power rating, bearing in mind that each additional lamp will absorb approximately 0.1A.

For calling at the floor use the note generator art. GN010 (see diagram on page 10).

N.B.

In order to avoid any noise (50Hz) in the speaker unit, lay the two 12V power supply cables of the transformer in a sheath separate from the other cables or install the transformer as near as possible the external unit.

Sc. SM102.003

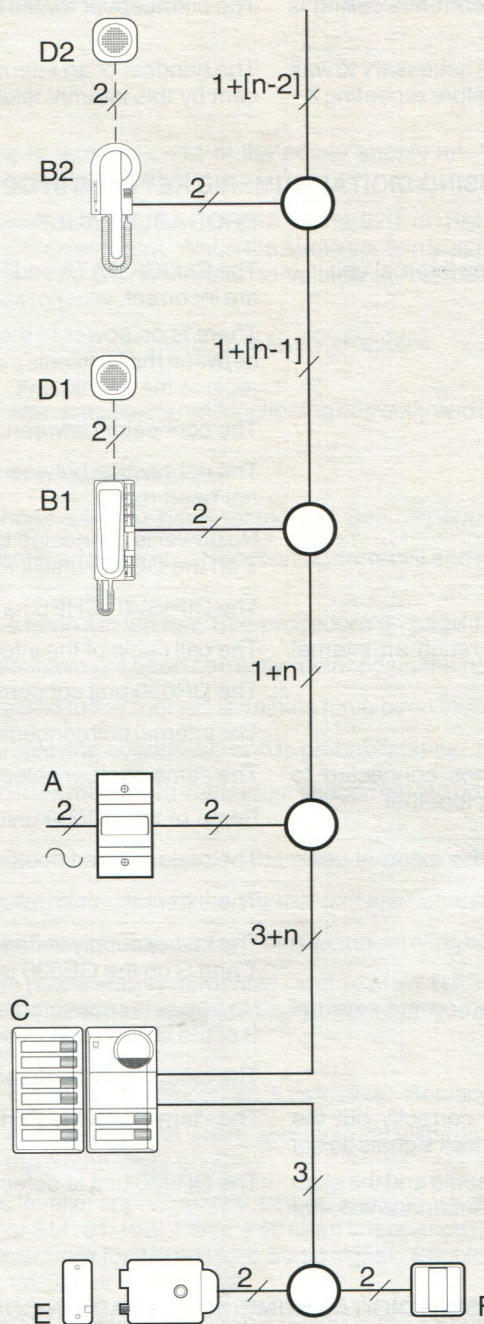

EQUIPMENT REQUIRED TO CARRY OUT INSTALLATION - TABLE 1

Diagram Ref. No.	Art.	Description	Quantity
A	TE1218	Transformer 12V-18VA	1
B	601CE PH620	Intercom Intercom	1:n
C	SM102/206	1000 series pushbutton panel	1
D	40.50N	Auxiliary sounder	1:n
E	-	Electric door lock	1
F	-	Door opening pushbutton	1

Sc.SM102.002

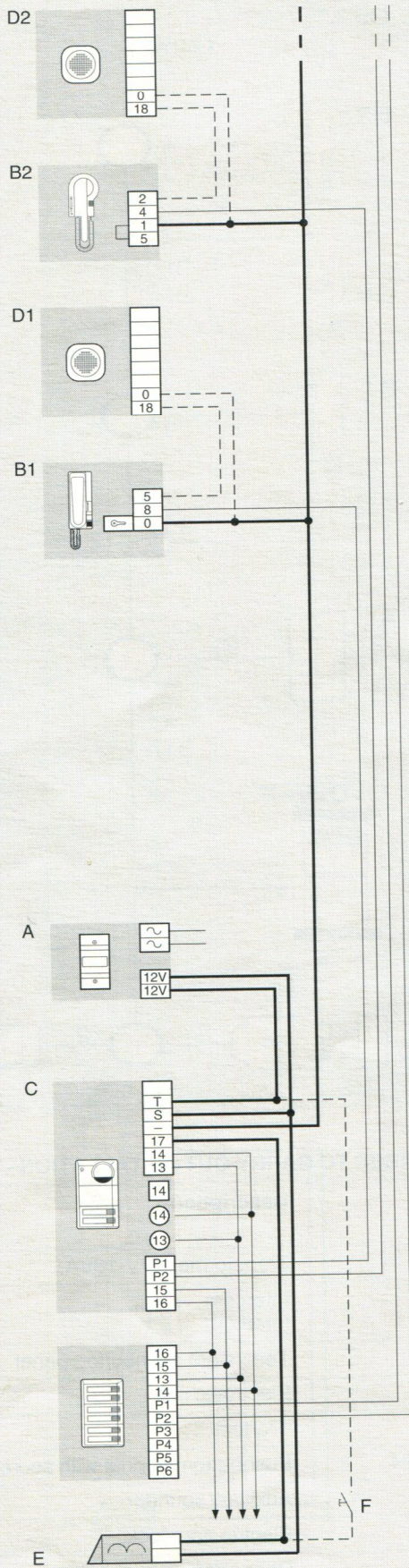

Electric porter installation with Tersystem pushbutton panels

Features

The installation allows conversation between the internal telephones and the electric porter. When the visitor at the entrance of the building presses the pushbutton on the pushbutton panel, an electronic call signal is sent to the selected internal telephone. The recipient may lift the handset and initiate a non timed conversation. The door opening control may be operated even with the handset on the hook. The installation is provided with secrecy. By pressing a key on the pushbutton panel, only the selected internal telephone is activated and all the others are disabled. This type of installation has the further advantage that, if at the end of the conversation the handset is not properly replaced on the hook, the internal telephone is automatically disabled from any subsequent call in such a way as not to bring the lowering of the audio level of the entire installation.

Implementation of the installation

- Select the required items by reference to table 2.
In the diagram, intercom art. PH620 and intercom 601CE are foreseen.
- Lay the cables in accordance with the connection diagram Sc. PH 620.002 in which the number of wires necessary for connection of the units is indicated.
It should be remembered that the cables should be of sufficient cross section for their length, as indicated in the table on page 10.
- Install and connect the units as shown in the diagram Sc. PH620.001 observing the installation requirements layed out on page 10.
- Test the installation as described on page 15.
The connections for the following optional facilities are shown in the diagram with dotted lines:

- additional sounder art. 40.50N
- pushbutton for actuating the electric door lock from the hallway.

The transformer TE1218 (12V 18VA) may be used to power 3 lamps 24V 3W as well as the rest of the installation. For pushbutton panels with more than 3 lamps, it will be necessary to make provisions for a 12V transformer having an adequate power rating, bearing in mind that each additional lamp will absorb approximately 0.1A.

For calling at the floor use the note generator art. GN010 (see diagram on page 10).

N.B.

In order to avoid any noise (50Hz) in the speaker unit, lay the two 12V power supply cables of the transformer in a sheath separate from the other cables or install the transformer as near as possible the external unit.

Sc. PH620.002

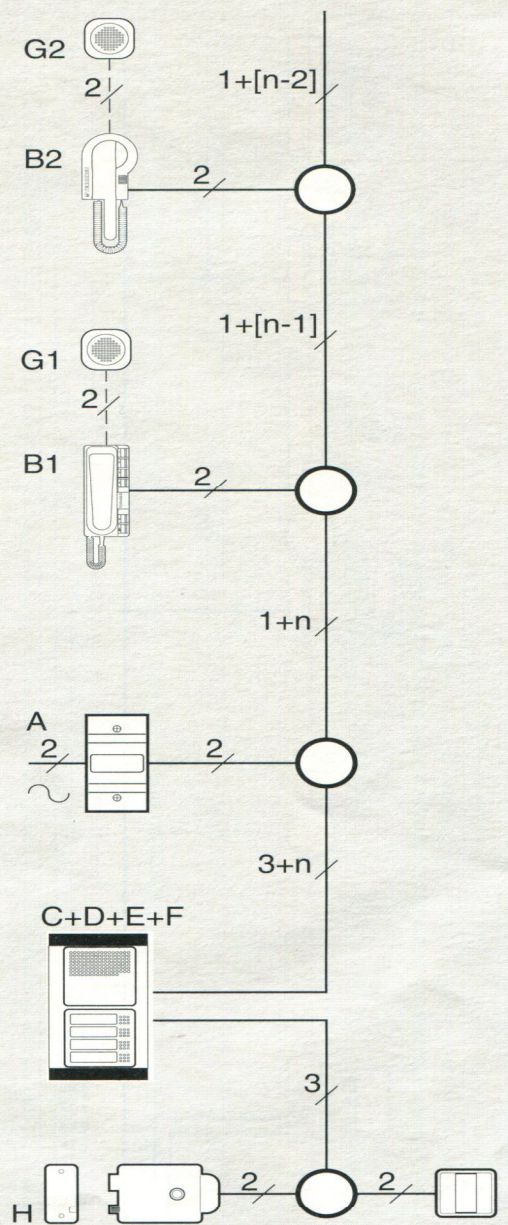

EQUIPMENT REQUIRED TO CARRY OUT INSTALLATION - TABLE 2

Diagram Ref. No.	Art.	Description	Quantity
A	TE1218	Transformer 12V-18VA	1
B	601CE PH620	Intercom Intercom	1÷n
C	2000	Tersystem pushbutton panel	1
D	GE020	Electronic unit	1
E	2170	"Porter"	1
F	2191-2194	Pushbutton module with secrecy	1÷n
G	40.50N	Auxiliary sounder	1÷n
H	-	Electric door lock	1
I	-	Door opening pushbutton	1

Sc.PH620.001

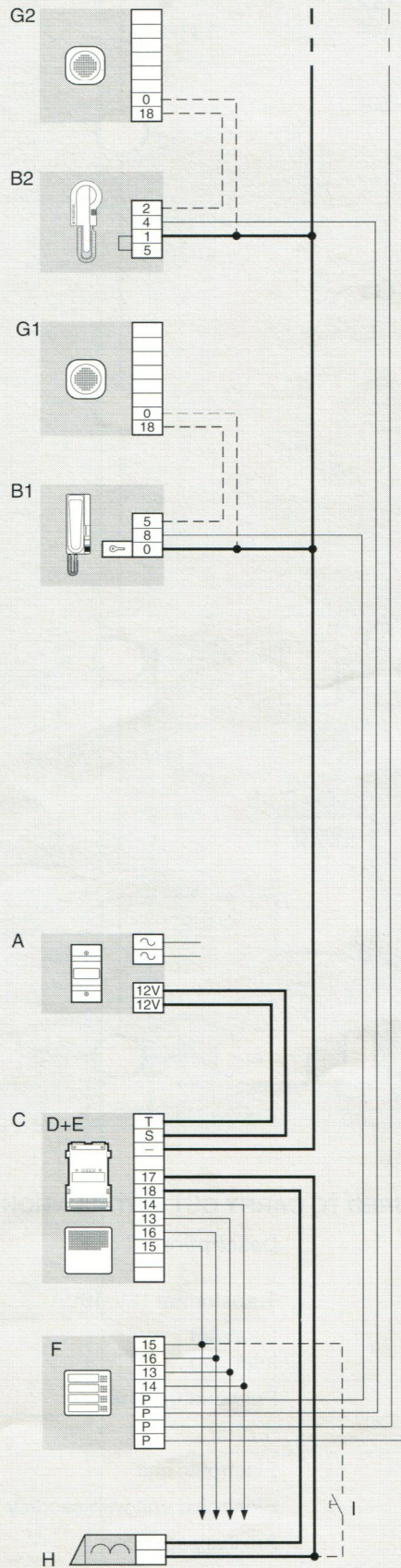

Electric porter installation with AV pushbutton panels

Features

The installation allows conversation between the internal telephones and the electric porter. When the visitor at the entrance of the building presses the pushbutton on the pushbutton panel, an electronic call signal is sent to the selected internal telephone. The recipient may lift the handset and initiate a non timed conversation. The door opening control may be operated even with the handset on the hook.

The AV series pushbutton panels are foreseen to accommodate the electronic power supply unit art. GE010 on the rear of the flush mounting box (refer to mounting instructions on page 13).

The GE010 is supplied as standard series with secrecy of conversation for 6 extensions; for installations with more than 6 intercoms mount the electronic unit art. UE008 in the additional pushbutton panel, one for every 8 pushbuttons.

Implementation of the installation

- Select the required items by reference to table 3.
In the diagram, intercom art. PH620 and intercom 601CE are foreseen.
- Lay the cables in accordance with the connection diagram Sc. PH620.005 in which the number of wires necessary for connection of the units is indicated.
It should be remembered that the cables should be of sufficient cross section for their length, as indicated in the table on page 10.
- Install and connect the units as shown in the diagram Sc. PH620.016 for installations up to 6 extensions or Sc. PH620.003 for installations with more than 6 extensions, observing the installation requirements laid out on page 10.
- Test the installation as described on page 15.

The connections for the following optional facilities are shown in the diagram with dotted lines.

- additional sounder art. 40.50N
- pushbutton for actuating the electric door lock from the hallway.

The transformer TE1218 (12V - 18VA) may be used to power 3 lamps 24V 3W as well as the rest of the installation.

For pushbutton panels with more than 3 lamps, it will be necessary to make provisions for a 12V transformer having an adequate power rating, bearing in mind that each additional lamp will absorb approximately 0.1A.

For calling at the floor use the note generator art. GN010 (see diagram on page 10).

N.B.

In order to avoid any noise (50Hz) in the speaker unit, lay the two 12V power supply cables of the transformer in a sheath separate from the other cables or install the transformer as near as possible the external unit.

Sc. PH 620.005

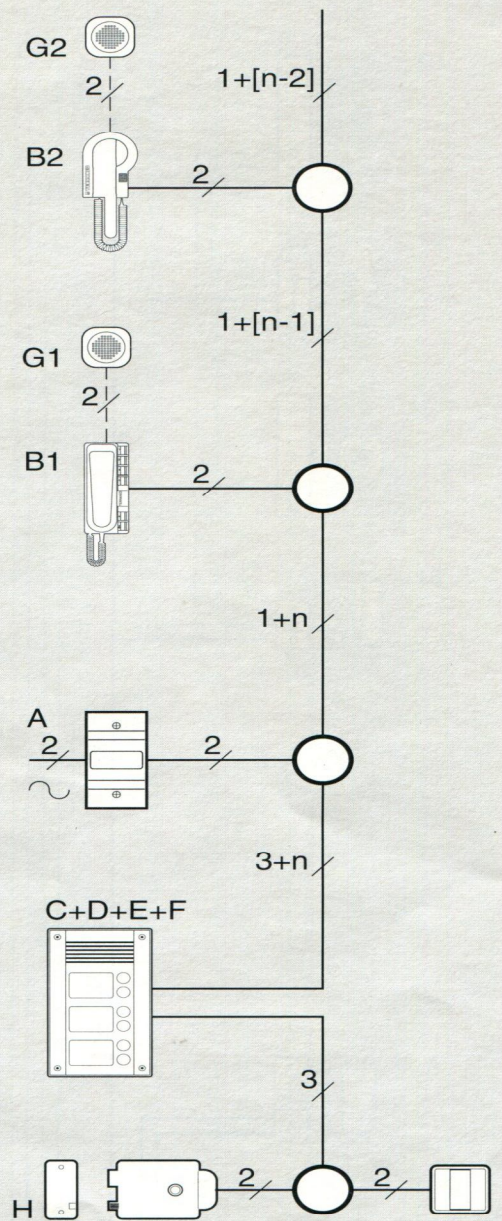

EQUIPMENT REQUIRED TO CARRY OUT INSTALLATION - TABLE 3

Diagram Ref. No.	Art.	Description	Quantity
A	TE1218	Transformer 12V-18VA	1
B	601CE PH620	Intercom Intercom	1÷n
C	AV	Pushbutton panel	1
D	2660	"Porter"	1
E	GE010	Electronic unit	1
F	UE008	Electronic unit with secrecy	1/8
G	40.50N	Auxiliary sounder	1÷n
H	-	Electric door lock	1
I	-	Door opening pushbutton	1

Sc.PH620.016

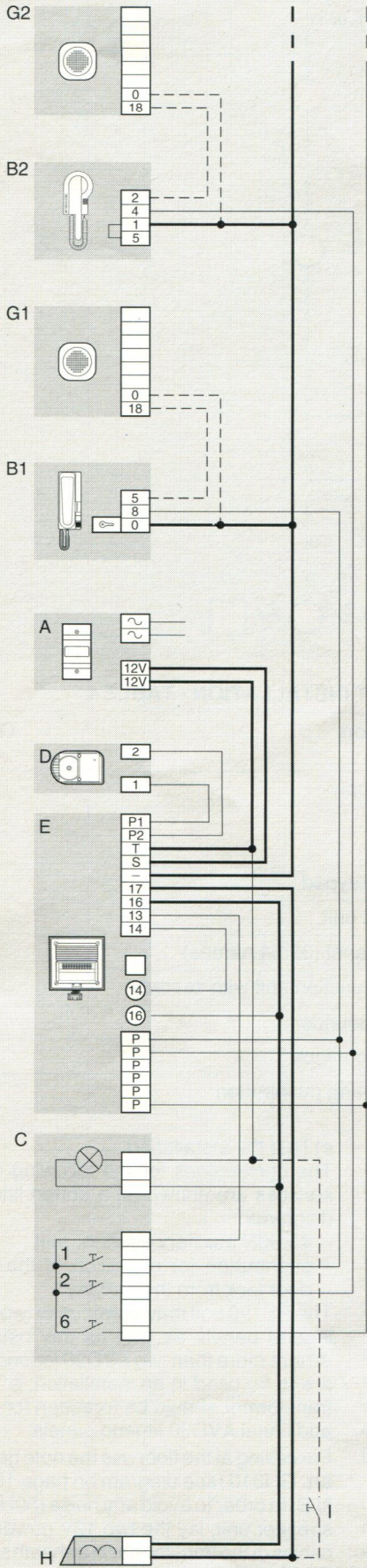

Sc.PH620.003

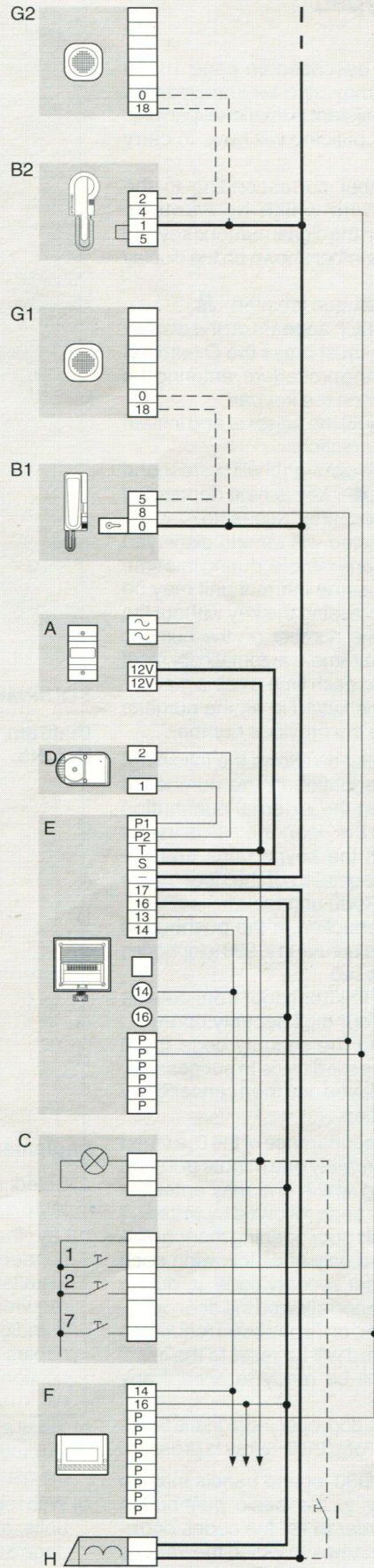

Electric porter installation with numeric keypad

Features

The installations described on page 18, 20 and on page 22 may also be implemented with the vandal-resistant numeric keypad unit. The visitor to the building will have to carry out the following:

- enter the number corresponding to the internal unit with which he wants to communicate, on the digital numeric keypad
- check that the number shown on the display is correct
- press the pushbutton labelled 
- if the number which appears on the display is incorrect, he must press the C (cancel) key and repeat the procedure, entering the correct number on the keypad.

The recipient may lift the handset and initiate a non timed conversation.

The duration of the call signal will correspond to the time the  key is held depressed plus an extra 4 sec. after releasing.

The number selected will remain displayed on the display for one minute; during this time other calls to the same internal unit may be made by simply pressing the key without the need to reenter the number on the numeric keypad. The display time is automatically reset for a further minute each time a call is made.

If a new number is keyed in on the numeric pad it will replace the previous number.

This type of installation allows the following:

- a significant reduction in the number of cables between the external pushbutton panel unit and the riser; the call is in fact digitised within the keypad unit and decoded at the beginning of the riser by the PS190 and DR030 units
- a significant reduction in the pushbutton panel size, inasmuch as up to 999 telephones may be addressed
- the opening of the front door from outside by entering a four digit security code. Before entering the security code the 0 key must be pressed twice in succession; the digit is displayed and then cancelled by this double action.

Following the disappearance of the 0, a timed period of approximately one minute duration is initiated, during which one may enter the four digit security code followed by pressing the 0→ key. This door opening manoeuvre may be requested only once following each entry of the correct security code; if, during the one minute period allowed the door opening is not requested or if it has been requested once, the keyboard will be reset to the initial condition and will be ready to accept any other operation.

The duration of the door opening signal is 5 sec. irrespective how long the 0→ key is pressed.

One or more AVD30 legend panels may be added optionally to the basic pushbutton keypad unit in order to list the codes corresponding to the names to which the various internal telephones belong. The installation is provided with secrecy.

Sc. GE030.003

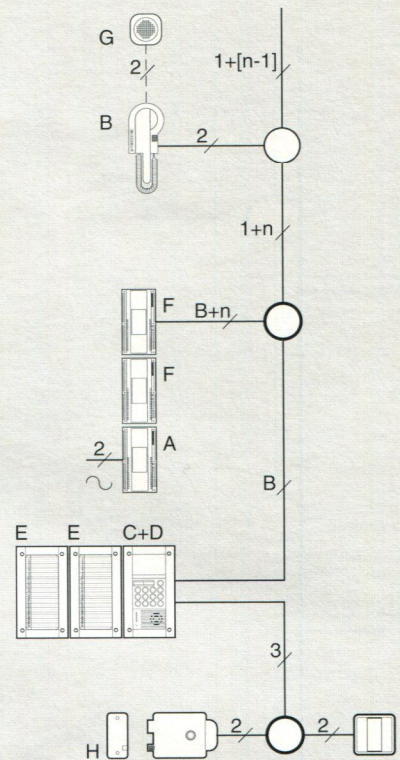

EQUIPMENT REQUIRED TO CARRY OUT INSTALLATION - TABLE 4

Diagram Ref. No.	Art.	Description	Quantity
A	PS190	Power supply	1
B	601CE PH620	Intercom Intercom	1÷n
C	AVD10	Numeric keypad	1
D	GE030	Electronic unit	1
E	AVD30	Legend panel (32/64 names)	1÷n
F	DR030	Decoder/junction unit with secrecy	1/10
G	40.50N	Auxiliary sounder	1÷n
H	-	Electric door lock	1
I	-	Door opening pushbutton	1

Implementation of the installation

- a) Select the items required by reference to table 4.
- b) Lay the wiring in accordance with the connection diagram Sc. GE030.003 for installations in which the number of cables required for the equipment interconnection is indicated. It should be noted that the cables should have an adequate cross section with respect to the length of the cable run, as shown in the table on page 10.
- c) Install and connect the items of equipment as indicated in diagram Sc. GE030.001, following the installation instructions given on page 10.
- d) With regard to the connection of the DR030 units, refer to the table on the diagram on page 34. In order to define the security code for operating the electric lock, refer to the instructions given on page 36.

e) Test the installation.

The connections for the following optional services are shown as a dotted line in the diagrams:

- 40.50N auxiliary sounder unit
- pushbutton for operation of the electric door lock from the hallway.

The PS190 unit may power up to two AVD30 legend panels as well as the installation. Where more than two AVD30 legend panels are to be used in an installation, a TE1218 transformer should be foreseen for every 5 additional AVD30 legend panels.

For calling at the floor use the note generator art. GN010 (see diagram on page 10).

N.B. In order to avoid any noise (50Hz) in the speaker unit, lay the two 12V power supply cables of the transformer in a sheath separate from the other cables or install the transformer as near as possible the external unit.

Sc.GE030.001

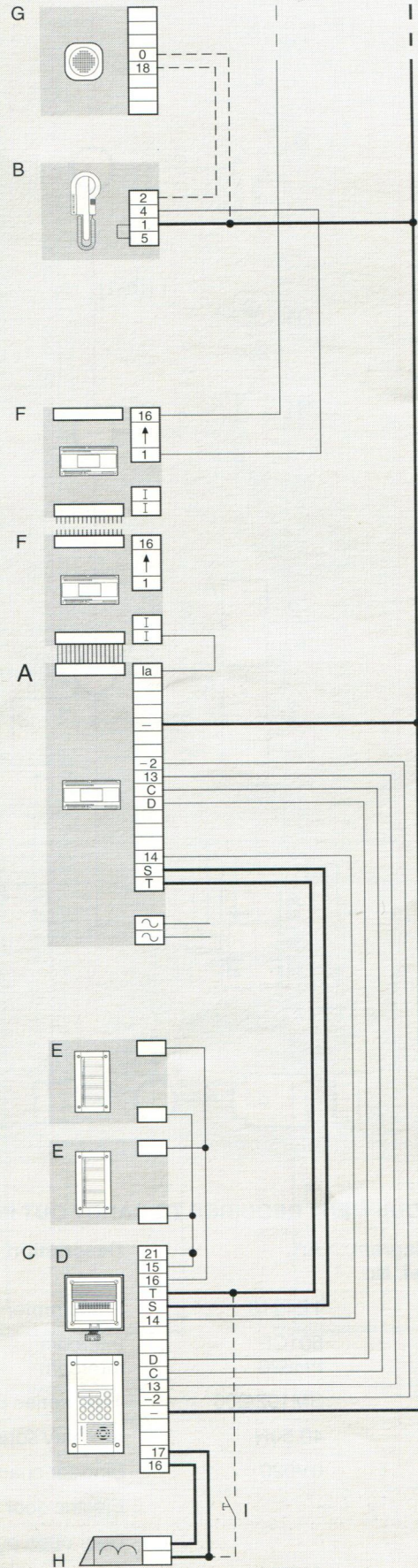

Electric porter installation with 2 external units using 1000 series pushbutton panel

Features

The installation allows connection between one of the external units and the selected internal telephone.

When the visitor presses a pushbutton on one of the external units, a call signal is sent to the selected internal telephone.

The changeover switch art. BV020 enables conversation and the door opening circuit connection for the external unit from which the call is being made.

The recipient may lift the handset and initiate a nontimed conversation. The "WAIT" indicator lights up at the disabled external unit (art. SM010).

The system is provided with secrecy.

By pressing a key on one of the two pushbutton panels, only the selected internal telephone is activated and all the others are disabled. This type of installation has the further advantage that, if at the end of the conversation the handset is not properly replaced on the hook, the internal telephone is automatically disabled from any subsequent call in such a way as not to bring about the lowering of the audio level of the entire installation.

Implementation of the installation

a) Select the required items by reference to table 5.

In the diagram, intercom art. PH620 and intercom 601CE are foreseen.

b) Lay the cables in accordance with the connection diagram Sc. SM102.005 in which the number of wires necessary for connection of the units is indicated.

It should be remembered that the cables should be of sufficient cross section for their length, as indicated in the table on page 10.

c) Install and connect the units as shown in the diagram Sc. SM102.004 observing the installation requirements laid out on page 10.

d) Test the installation as described on page 15. The connections for the following optional facilities are shown in the diagram with dotted lines:

- additional sounder art. 40.50N
- pushbutton for actuating the electric door lock from the hallway.

The transformer TE1218 (12V 18VA) may be used to power one 24V 3W pushbutton illuminating lamp and one indicator lamp for the "WAIT" sign as well as the rest of the installation. For installations having pushbutton panels with more than one pushbutton illumination lamp, it will be necessary to make provisions for a transformer having an adequate power rating, bearing in mind that each additional lamp will absorb approximately 0.1A.

N.B. In order to avoid any noise (50Hz) in the speaker unit, lay the two 12V power supply cables of the transformer in a sheath separate from the other cables or install the transformer as near as possible the external unit.

Sc. SM102.005

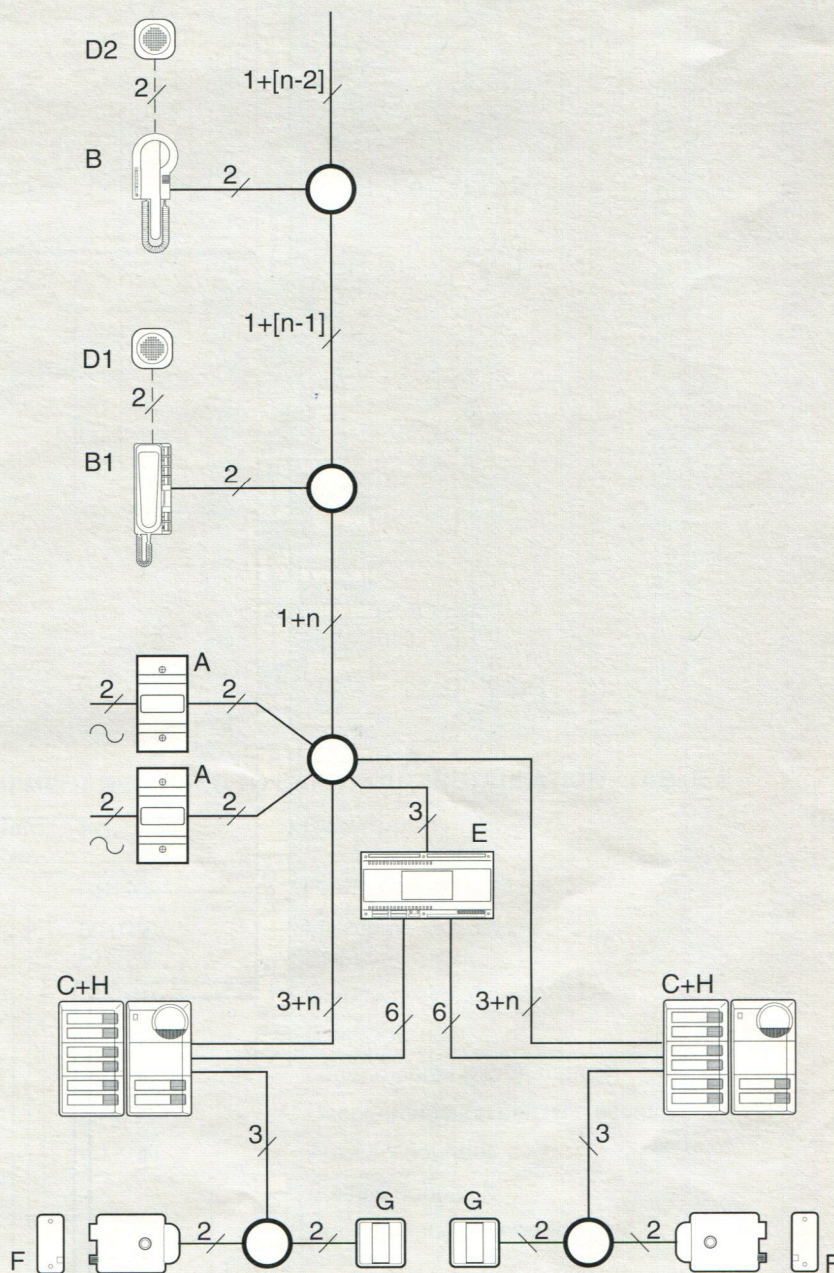

EQUIPMENT REQUIRED TO CARRY OUT INSTALLATION - TABLE 5

Diagram Ref. No.	Art.	Description	Quantity
A	TE1218	Transformer 12V-18VA	2
B	601CE PH620	Intercom Intercom	1÷n
C	SM102/206	1000 series pushbutton panels	2
D	40.50N	Auxiliary sounder	1÷n
E	BV020	Biporter changeover switch	1
F	-	Electric door lock	2
G	-	Door open pushbutton	2
H	SM010	Illuminated "WAIT" signal	2

Sc.SM102.004

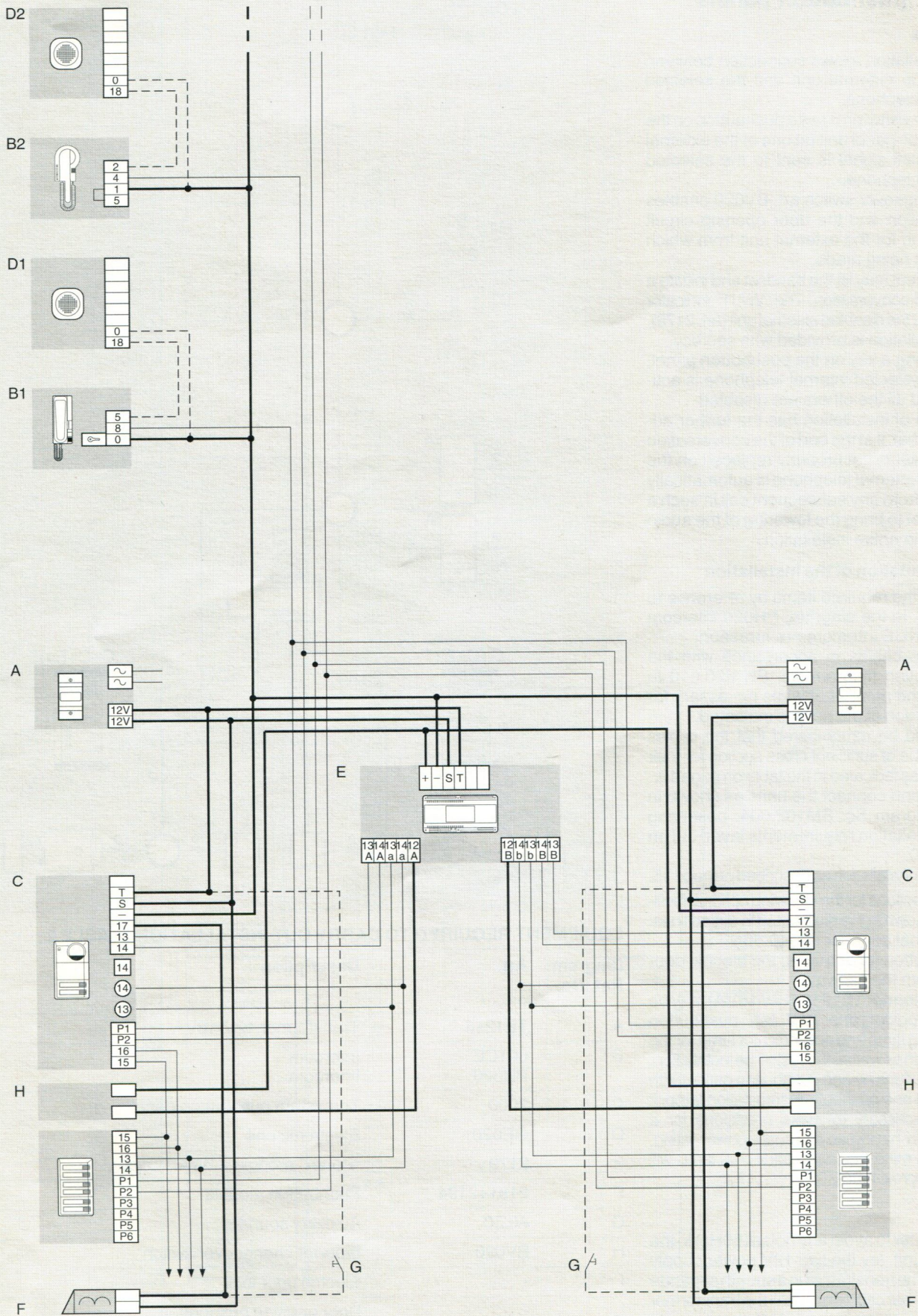

Electric porter installation with 2 external units using Tersystem series pushbutton panels

Features

The installation allows connection between one of the external unit and the selected internal telephone.

When the visitor presses a pushbutton on the pushbutton panel unit on one of the external units, a call signal is sent to the selected internal telephone.

The changeover switch art. BV020 enables conversation and the door opening circuit connection for the external unit from which the call is being made.

The recipient may lift the handset and initiate a non timed conversation. The "WAIT" indicator lights up at the disabled external unit (art. 2179). The installation is provided with secrecy.

By pressing a key on the pushbutton panel, only the selected internal telephone is activated and all the others are disabled.

This type of installation has the further advantage that, if at the end of the conversation the handset is not properly replaced on the hook, the internal telephone is automatically disabled from any subsequent call in such a way as not to bring the lowering of the audio level of the entire installation.

Implementation of the installation

- Select the required items by reference to table 6. In the diagram, PH620 intercom and 601CE intercom are foreseen.
- Lay the cables in accordance with the connection diagram Sc. PH 620.010 in which the number of wires necessary for connection of the units is indicated.
It should be remembered that the cables should be of sufficient cross section for their length, as indicated in the table on page 10.
- Install and connect the units as shown in the diagram Sc. SM102.004, observing the installation requirements laid out on page 10.
- Test the installation as described on page 15.

The connections for the following optional facilities are shown in the diagram with dotted lines:

- additional sounder art. 40.50N
- pushbutton for actuating the electric door lock from the hallway.

The transformer TE1218 (12V 18VA) may be used to power one 24V 3W pushbutton illuminating lamp and one indicator lamp for the "WAIT" sign as well as the rest of the installation. For installations having pushbutton panels with more than one pushbutton illumination lamp, it will be necessary to make provisions for a transformer having an adequate power rating, bearing in mind that each additional lamp will absorb approximately 0.1A.

N.B. In order to avoid any noise (50Hz) in the speaker unit, lay the two 12V power supply cables of the transformer in a sheath separate from the other cables or install the transformer as near as possible the external unit.

Sc. PH620.010

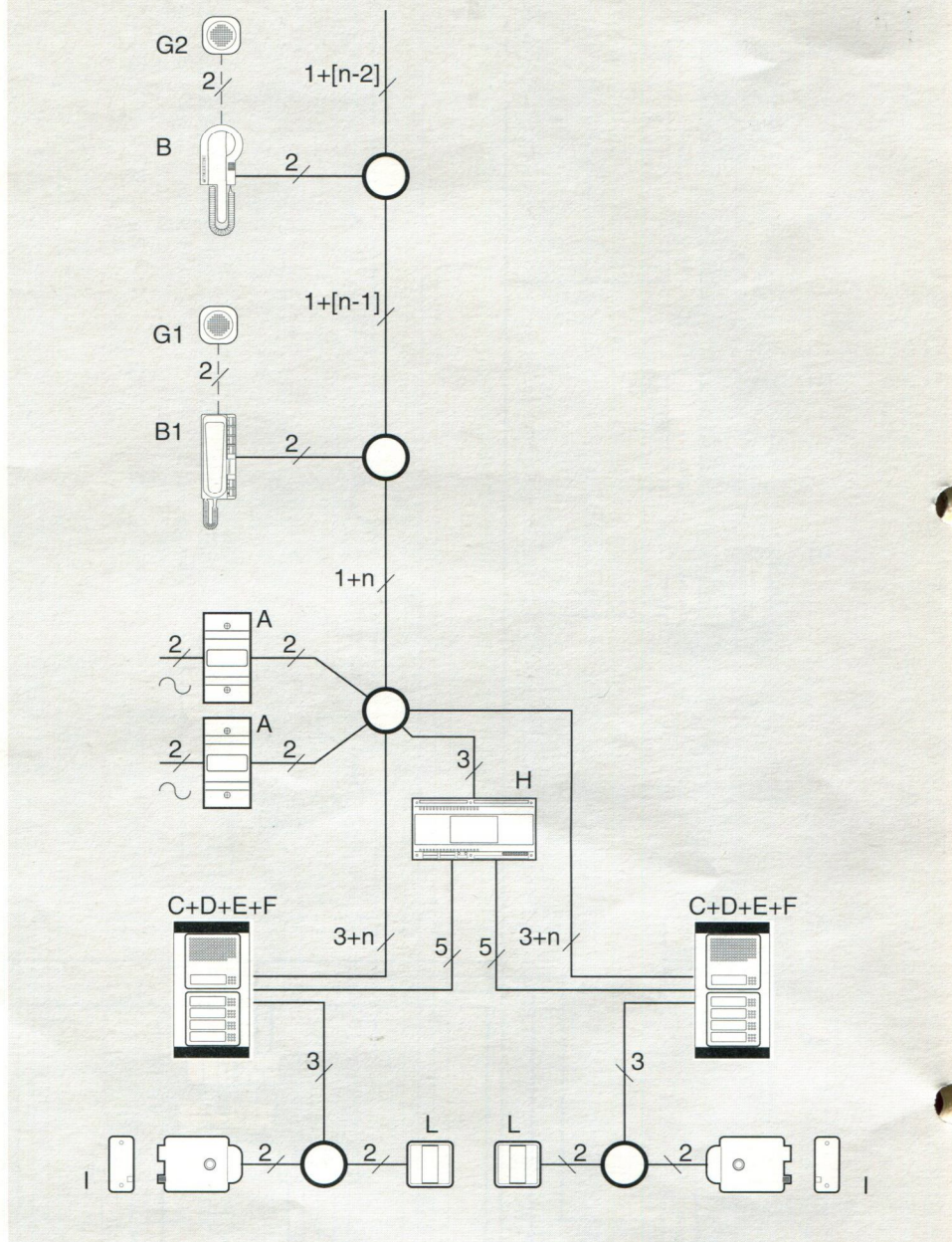

EQUIPMENT REQUIRED TO CARRY OUT INSTALLATION - TABLE 6

Diagram Ref. No.	Art.	Description	Quantity
A	TE1218	Transformer 12V-18VA	2
B	601CE PH620	Intercom Intercom	1÷n
C	2000	Tersystem pushbutton panel	2
D	GE020	Electronic unit	2
E	2179	"Porter" module + "WAIT" signal	2
F	2191÷2194	Pushbutton module	1÷n
G	40.50	Auxiliary sounder	1÷n
H	BV020	Biporter changeover switch	1
I	-	Electric door lock	2
L	-	Door opening pushbutton	2

Sc.PH620.009

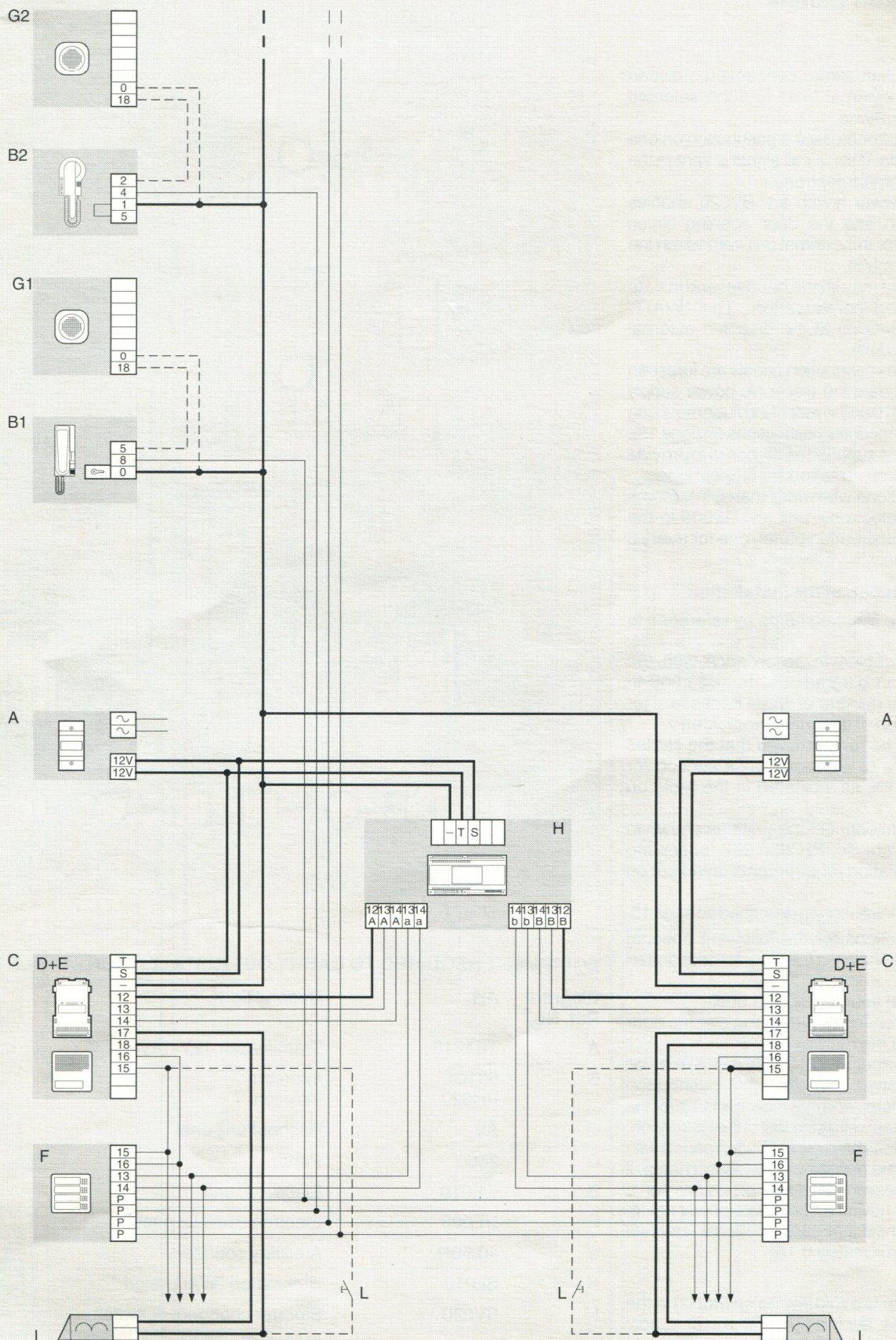

Electric porter installation with 2 external units using AV series pushbutton panels

Features

The installation allows connection between one of the external units and the selected internal telephone.

When the visitor presses a pushbutton on one of the external units, a call signal is sent to the selected internal telephone.

The changeover switch art. BV020 enables conversation and the door opening circuit connection for the external unit from which the call is being made.

The recipient may lift the handset and initiate a non timed conversation. The "WAIT" indicator lights up at the disabled external unit (art. SL010).

The AV series pushbutton panels are foreseen to accommodate the electronic power supply unit art. GE010 on the rear of the flush mounting box (refer to mounting instructions on page 13). The GE010 is supplied as standard to provide secrecy of conversation for 6 telephones.

For installations with more than 6 intercoms mount the electronic unit art. UE008 in the additional pushbutton panel, one for every 8 pushbuttons.

Implementation of the installation

- Select the required items by reference to table 7.
- Lay the cables in accordance with the connection diagram Sc. PH 620.008 in which the number of wires necessary for connection of the units is indicated. It should be remembered that the cables should be of sufficient cross section for their length, as indicated in the table on page 10.
- Install and connect the units as shown in the diagram Sc. PH 620.007, observing the installation requirements layed out on page 10.
- Test the installation as described on page 15.

The connections for the following optional facilities are shown in the diagram with dotted lines:

- additional sounder art. 40.50N
- pushbutton for actuating the electric door lock from the hallway.

The transformer TE1218 (12V 18VA) may be used to power one 24V 3W pushbutton illuminating lamp and one indicator lamp for the "WAIT" sign as well as the rest of the installation. For installations having pushbutton panels with more than one pushbutton illumination lamp, it will be necessary to make provisions for a transformer having an adequate power rating, bearing in mind that each additional lamp will absorb approximately 0.1A.

N.B. In order to avoid any noise (50Hz) in the speaker unit, lay the two 12V power supply cables of the transformer in a sheath separate from the other cables or install the transformer as near as possible the external unit.

Sc. PH620.008

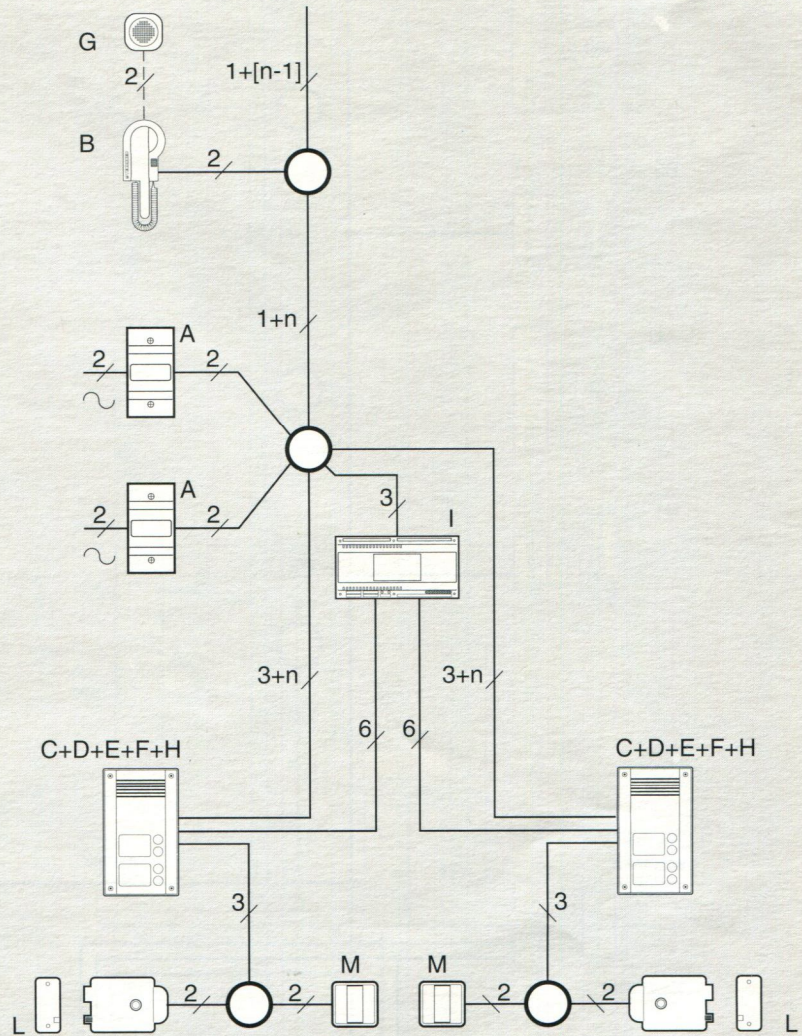

EQUIPMENT REQUIRED TO CARRY OUT INSTALLATION - TABLE 7

Diagram Ref. No.	Art.	Description	Quantity
A	TE1218	Transformer 12V-18VA	2
B	601CE PH620	Intercom Intercom	1÷n
C	AV	Pushbutton panel	2
D	2660	Porter	2
E	GE010	Electronic unit	2
F	UE008	Electronic unit for secrecy	1/8
G	40.50N	Auxiliary sounder	1÷n
H	SL010	Illuminated "WAIT" sign	2
I	BV020	Biporter changeover switch	1
L	-	Electric door lock	2
M	-	Door opening pushbutton	2

Sc.PH620.007

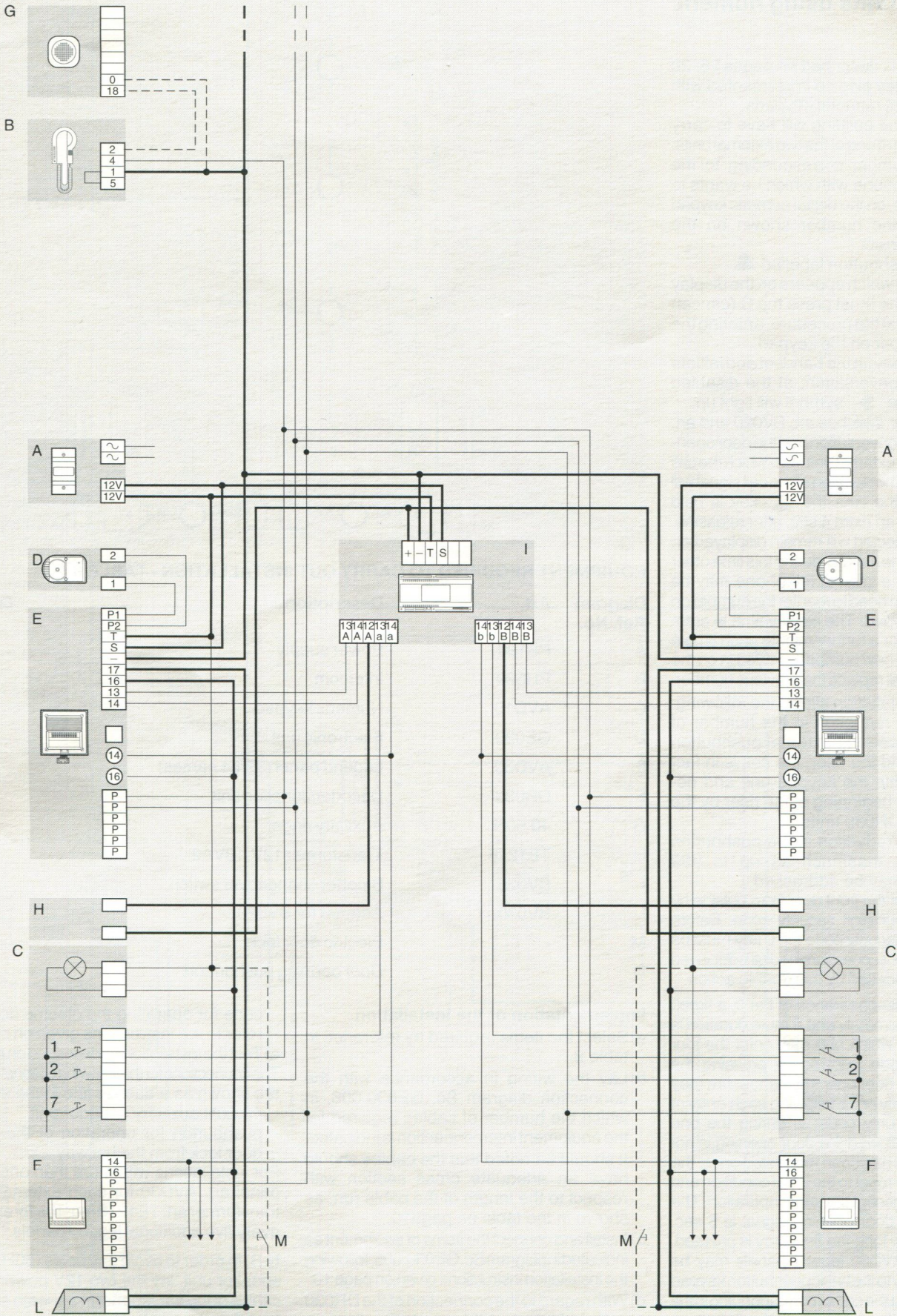



Electric porter installation with 2 external units using numeric keypad

The installations described on pages 26, 28 and page 30 may also be implemented with vandal-resistant numeric keypads.

The visitor to the building will have to carry out the following at one of the two external units:

- enter the number corresponding to the internal telephone with which he wants to communicate, on the digital numeric keypad
- check that the number shown on the display is correct
- press the pushbutton labelled 
- if the number which appears on the display is incorrect, he must press the C (cancel) key and repeat the procedure, entering the correct number on the keypad.

The recipient may lift the handset and initiate a non timed conversation; at the disabled external unit the  symbol will light up.

The changeover switches art. BV020 and art. BV030 enable conversation and the door opening circuit for the external unit from which the call is being made. The duration of the call signal will correspond to the time the  key is held depressed plus an extra 4 sec. after releasing. The number selected will remain displayed on the display for one minute; during this time other calls to the same internal telephone may be made without the need to reenter the number on the numeric keypad. The display time is automatically reset for a further minute each time a call is made. If a new number is keyed in on the numeric pad it will replace the previous number.

This type of installation allows the following:

- a significant reduction in the number of cables between the external pushbutton panel unit and the riser; the call is in fact digitised within the keypad unit and decoded at the beginning of the riser by the PS190 and DR030 units
- a significant reduction in the pushbutton panel itself, inasmuch as up to 999 extensions may be addressed
- the opening of the front door from outside by entering a four digit security code. Before entering the security code the 0 key must be pressed twice in succession; the digit is displayed and then cancelled by this double action.

Following the disappearance of the 0, a timed period of approximately one minute duration is initiated, during which one may enter the four digit security code followed by pressing the 0 key. This door opening manoeuvre may be requested only once following each entry of the correct security code; if, during the one minute period allowed the door opening is not requested or if it has been requested once, the keyboard will be reset to the initial condition and will be ready to accept any other operation. The duration of the door opening signal is 5 sec. irrespective how long the 0 key is pressed. One or more AVD30 legend panels may be added optionally to the basic pushbutton keypad unit in order to list the codes corresponding to the names to which the various internal units belong. The installation is provided with secrecy.

Sc. GE030.006

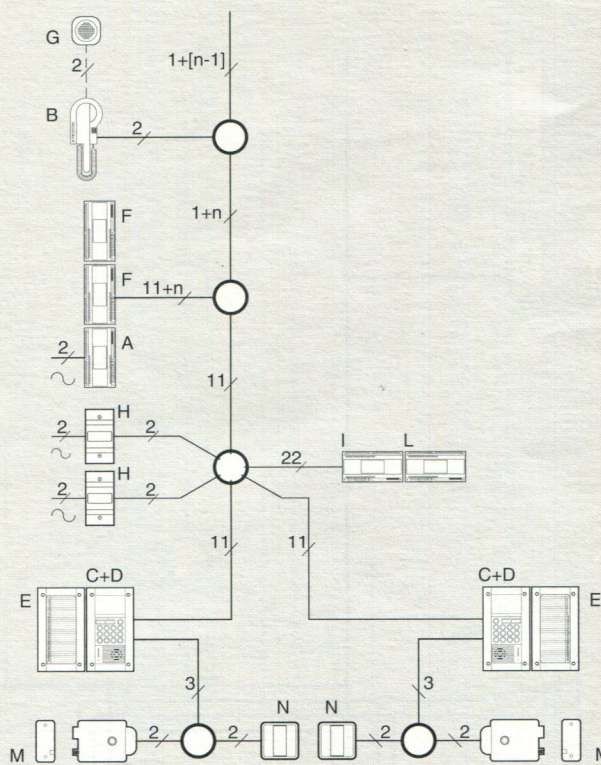

EQUIPMENT REQUIRED TO CARRY OUT INSTALLATION - TABLE 8

Diagram Ref. No.	Art.	Description	Quantity
A	PS190	Power supply	1
B	PH620	Intercom	1:n
C	AVD10	Numeric keypad	2
D	GE030	Electronic unit	2
E	AVD30	Legend panel (32/64 names)	1:n
F	DR030	Decoder/Junction unit	1/16
G	40.50N	Auxiliary ringer	1:n
H	TE1218	Transformer 12V-18VA2	2
I	BV020	Biporter changeover switch	1
L	BV030	Adaptor for BV020	1
M	-	Electric door lock	2
N	-	Door opening pushbutton	2

Implementation of the installation

- a) Select the items required by reference to table 8.
- b) Lay the wiring in accordance with the connection diagram Sc. GE030.006, in which the number of cables required for the equipment interconnection is indicated. It should be noted that the cables should have an adequate cross section with respect to the length of the cable run, as shown in the table on page 10.
- c) Install and connect the items of equipment as indicated in diagram Sc. GE030.005, following the installation instructions given on page 10.
- d) With regard to the connection of the DR030 units, refer to the table and to the diagram on page 34. In order to define the security

code for operating the electric door lock, refer to the instructions given on page 36.

e) Test the installation as described on page 15. The connections for the following optional services are shown as a dashed line in the diagram:

- 40.50N auxiliary sounder unit
- pushbutton for operation of the electric door lock from the hallway.

For installations with more than one legend panel art. AVD30 for each external unit, a transformer art. TE1218 must be foreseen for every five additional legend panels.

N.B. In order to avoid any noise (50Hz) in the speaker unit, lay the two 12V power supply cables of the transformer in a sheath separate from the other cables or install the transformer as near as possible the external unit.

Sc.GE030.005

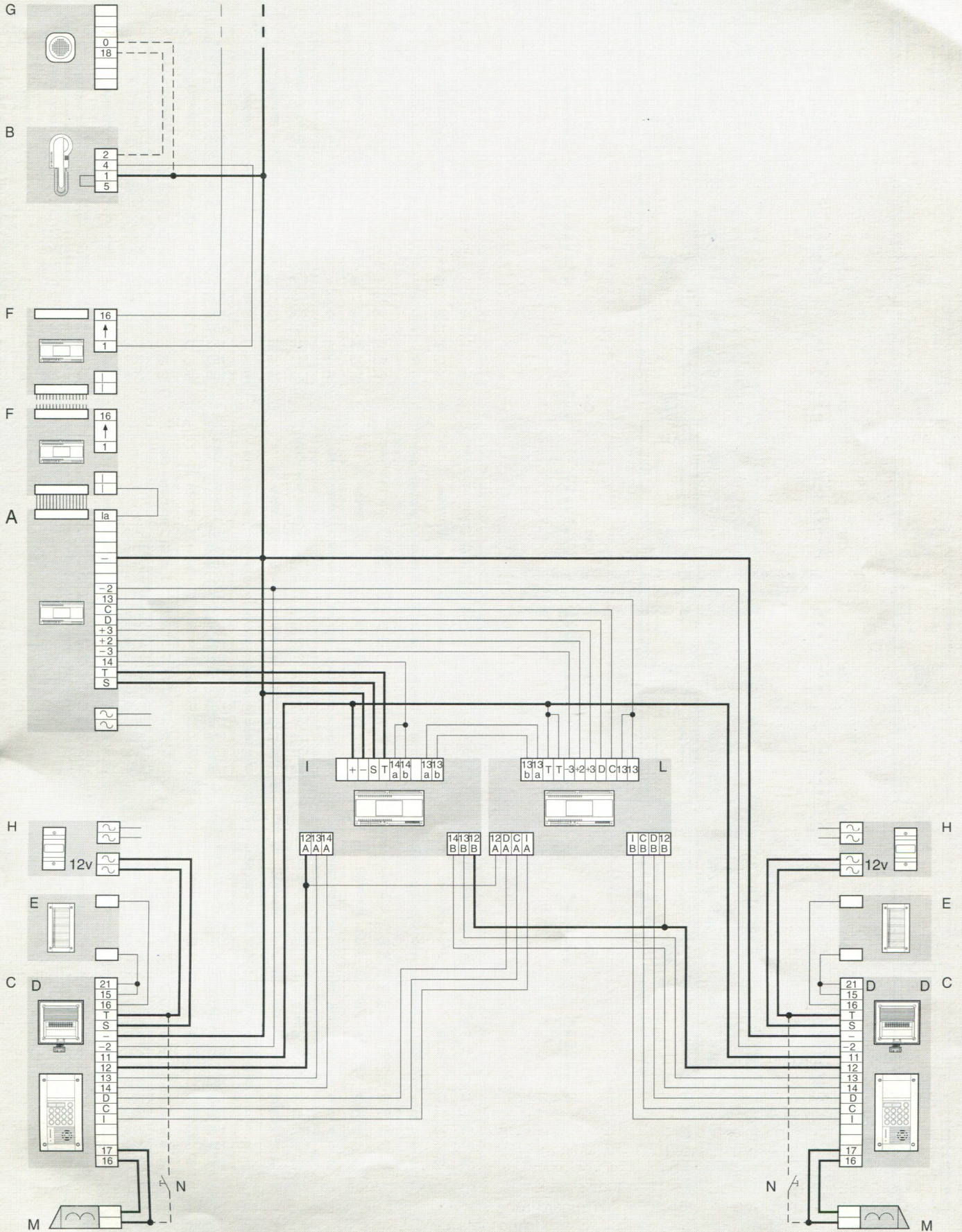

Connection diagram of 16 art. DR030 units for 256 telephones

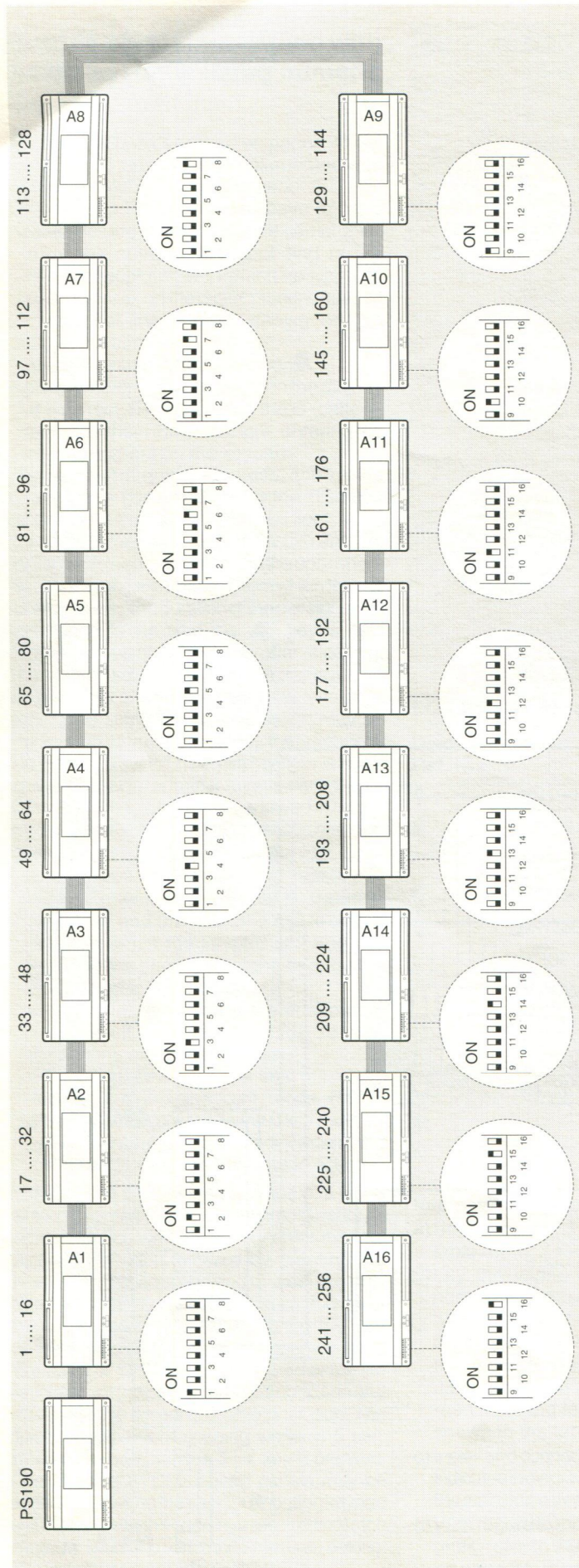

NO. OF TELEPHONES	A1			A4			A7			A10			A13			A16		
	TERMINAL	DIP SWITCH (ON)		TERMINAL	DIP SWITCH (ON)		TERMINAL	DIP SWITCH (ON)		TERMINAL	DIP SWITCH (ON)		TERMINAL	DIP SWITCH (ON)		TERMINAL	DIP SWITCH (ON)	
1	1	1		49	1	4	97	1	7	145	1	10	193	1	13	241	1	16
2	2	1		50	2	4	98	2	7	146	2	10	194	2	13	242	2	16
3	3	1		51	3	4	99	3	7	147	3	10	195	3	13	243	3	16
4	4	1		52	4	4	100	4	7	148	4	10	196	4	13	244	4	16
5	5	1		53	1	4	101	1	7	149	1	10	197	1	13	245	1	16
6	6	1		54	6	4	102	6	7	150	6	10	198	6	13	246	6	16
7	7	1		55	7	4	103	7	7	151	7	10	199	7	13	247	7	16
8	8	1		56	8	4	104	8	7	152	8	10	200	8	13	248	8	16
9	9	1		57	9	4	105	9	7	153	9	10	201	9	13	249	9	16
10	10	1		58	10	4	106	10	7	154	10	10	202	10	13	250	10	16
11	11	1		59	11	4	107	11	7	155	11	10	203	11	13	251	11	16
12	12	1		60	12	4	108	12	7	156	12	10	204	12	13	252	12	16
13	13	1		61	13	4	109	13	7	157	13	10	205	13	13	253	13	16
14	14	1		62	14	4	110	14	7	158	14	10	206	14	13	254	14	16
15	15	1		63	15	4	111	15	7	159	15	10	207	15	13	255	15	16
16	16	1		64	16	4	112	16	7	160	16	10	208	16	13	256	16	16

NO. OF TELEPHONES	A2			A5			A8			A11			A14		
	TERMINAL	DIP SWITCH (ON)		TERMINAL	DIP SWITCH (ON)		TERMINAL	DIP SWITCH (ON)		TERMINAL	DIP SWITCH (ON)		TERMINAL	DIP SWITCH (ON)	
17	1	2		65	1	5	113	1	8	161	1	11	209	1	14
18	2	2		66	2	5	114	2	8	162	2	11	210	2	14
19	3	2		67	3	5	115	3	8	163	3	11	211	3	14
20	4	2		68	4	5	116	4	8	164	4	11	212	4	14
21	1	2		69	1	5	117	1	8	165	1	11	213	1	14
22	6	2		70	6	5	118	6	8	166	6	11	214	6	14
23	7	2		71	7	5	119	7	8	167	7	11	215	7	14
24	8	2		72	8	5	120	8	8	168	8	11	216	8	14
25	9	2		73	9	5	121	9	8	169	9	11	217	9	14
26	10	2		74	10	5	122	10	8	170	10	11	218	10	14
27	11	2		75	11	5	123	11	8	171	11	11	219	11	14
28	12	2		76	12	5	124	12	8	172	12	11	220	12	14
29	13	2		77	13	5	125	13	8	173	13	11	221	13	14
30	14	2		78	14	5	126	14	8	174	14	11	222	14	14
31	15	2		79	15	5	127	15	8	175	15	11	223	15	14
32	16	2		80	16	5	128	16	8	176	16	11	224	16	14

NO. OF TELEPHONES	A3			A6			A9			A12			A15		
	TERMINAL	DIP SWITCH (ON)		TERMINAL	DIP SWITCH (ON)		TERMINAL	DIP SWITCH (ON)		TERMINAL	DIP SWITCH (ON)		TERMINAL	DIP SWITCH (ON)	
33	1	3		81	1	6	129	1	9	177	1	12	225	1	15
34	2	3		82	2	6	130	2	9	178	2	12	226	2	15
35	3	3		83	3	6	131	3	9	179	3	12	227	3	15
36	4	3		84	4	6	132	4	9	180	4	12	228	4	15
37	1	3		85	1	6	133	1	9	181	1	12	229	1	15
38	6	3		86	6	6	134	6	9	182	6	12	230	6	15
39	7	3		87	7	6	135	7	9	183	7	12	231	7	15
40	8	3		88	8	6	136	8	9	184	8	12	232	8	15
41	9	3		89	9	6	137	9	9	185	9	12	233	9	15
42	10	3		90	10	6	138	10	9	186	10	12	234	10	15
43	11	3		91	11	6	139	11	9	187	11	12	235	11	15
44	12	3		92	12	6	140	12	9	188	12	12	236	12	15
45	13	3		93	13	6	141	13	9	189	13	12	237	13	15
46	14	3		94	14	6	142	14	9	190	14	12	238	14	15
47	15	3		95	15	6	143	15	9	191	15	12	239	15	15
48	16	3		96	16	6	144	16	9	192	16	12	240	16	15

Connection diagram of 63 art. DR030 units for 999 telephones

Sc.GE030.012

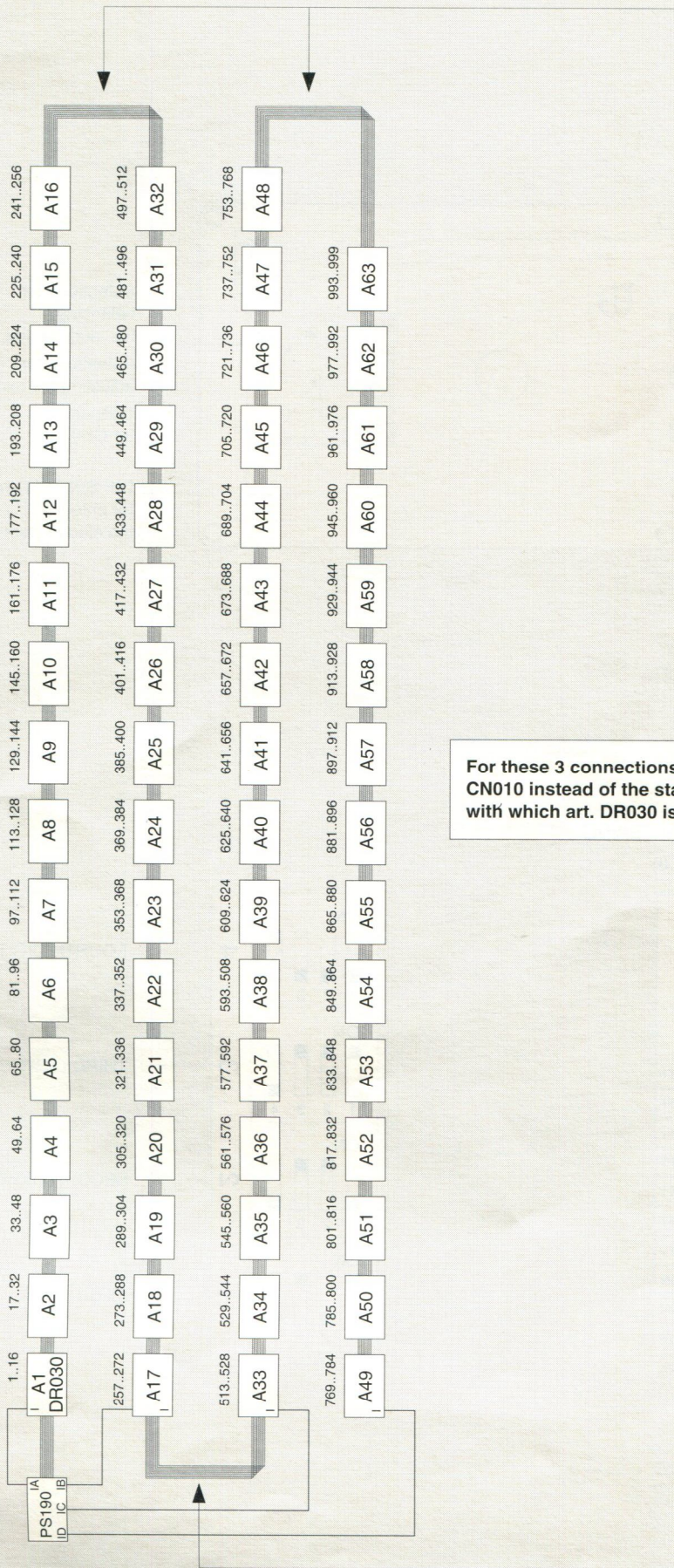

For these 3 connections use connector art. CN010 instead of the standard connector with which art. DR030 is equipped.

Door lock security coding in installations with numeric keypad

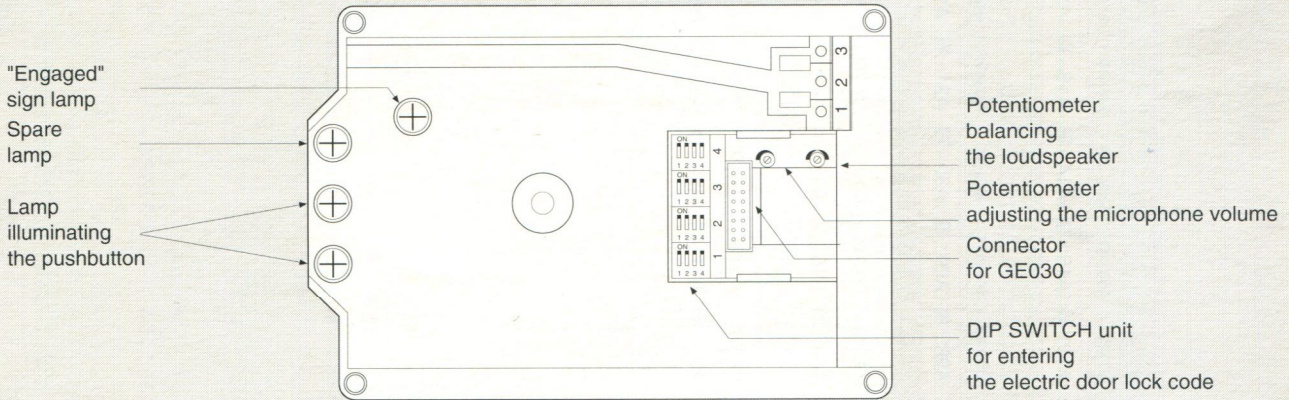

EXAMPLE OF CODE ENTERING
(0 0 5 6 7 8)

DECIMAL NUMBER CORRESPONDING TO DIP SWITCH SETTING	DIP SWITCH SETTING			
	ON	OFF	OFF	OFF
1	ON	OFF	OFF	OFF
2	OFF	ON	OFF	OFF
3	ON	ON	OFF	OFF
4	OFF	OFF	ON	OFF
5	ON	OFF	ON	OFF
6	OFF	ON	ON	OFF
7	ON	ON	ON	OFF
8	OFF	OFF	OFF	ON
9	ON	OFF	OFF	ON
0	OFF	OFF	OFF	OFF

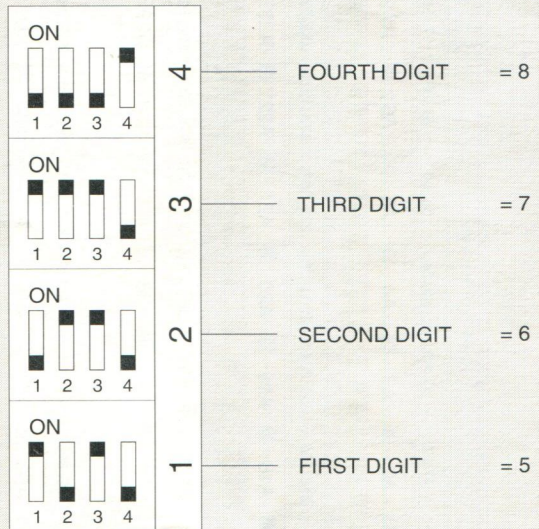

LT Terraneo spa

Via L. Manara, 4
22036 Erba Como Italy
Tel. 031.641438 r.a.
Telex 322140 ELLETI I
Fax 031.645037